

UL/cUL SYSTEM NO. W-L-3272
CABLE BUNDLE THROUGH 1-HR. OR 2-HR. GYPSUM WALL ASSEMBLY

F-RATING = 1-HR. OR 2-HR.

T-RATING = 0-HR.

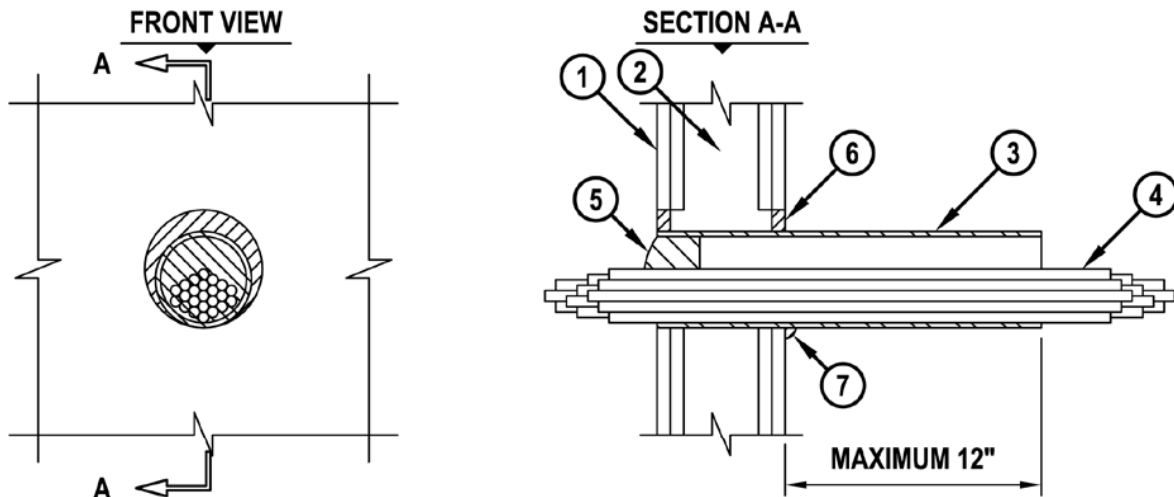

WL3272b.022805

1. GYPSUM WALL ASSEMBLY (UL/cUL CLASSIFIED U300, U400 OR V400 SERIES) (1-HR. OR 2-HR. FIRE-RATING).
2. [NOT SHOWN] WOOD STUDS TO CONSIST OF NOMINAL 2" x 4" LUMBER. STEEL STUDS TO BE MINIMUM 3-1/2" WIDE.
3. MAXIMUM 4" NOMINAL DIAMETER STEEL PIPE SLEEVE (SCHEDULE 5 OR HEAVIER). SLEEVE MAY EXTEND UP TO 12" BEYOND WALL SURFACE IN ANY COMBINATION (SEE NOTE NO. 4 BELOW).
4. CABLE BUNDLE TO BE A COMBINATION OF ANY OF THE FOLLOWING :
 - A. MAXIMUM 300 PAIR NO. 24 AWG TELEPHONE CABLE WITH PVC JACKET.
 - B. MAXIMUM 750 KCMIL POWER CABLE WITH PVC JACKET.
 - C. MAXIMUM 7/C NO. 12 AWG POWER CABLE WITH PVC JACKET.
 - D. MAXIMUM 1/2" DIAMETER FIBER-OPTIC CABLE (MAXIMUM 24 FIBER).
 - E. MAXIMUM 3/C NO. 12 AWG METAL-CLAD CABLE WITH PVC JACKET.
 - F. MAXIMUM 1" DIAMETER METAL-CLAD TEK CABLE WITH PVC JACKET.
5. ONE HILTI CP 658T FIRESTOP PLUG CUT TO FIT AROUND THE CABLE BUNDLE AND INSTALLED TIGHTLY WITHIN SLEEVE SUCH THAT THE OUTER CIRCUMFERENCE OF THE DOME SHAPED PLUG IS FLUSH WITH EITHER END OF SLEEVE.
6. MINIMUM 5/8" DEPTH HILTI FS-ONE INTUMESCENT FIRESTOP SEALANT TO BE APPLIED WHEN ANNULAR SPACE EXISTS.
7. MINIMUM 1/2" BEAD HILTI FS-ONE INTUMESCENT FIRESTOP SEALANT APPLIED AT SLEEVE/WALL INTERFACE WHEN SLEEVE EXTENDS PAST WALL.

NOTES : 1. MAXIMUM DIAMETER OF OPENING = 5-1/2".
 2. ANNULAR SPACE = MINIMUM 0", MAXIMUM 1".
 3. CABLES TO FILL MAXIMUM 50% OF CROSS-SECTIONAL AREA OF THE OPENING.
 4. SLEEVE TO BE RIGIDLY SUPPORTED WHEN EXTENDING MORE THAN 2" BEYOND WALL SURFACE.

Hilti. Outperform. Outlast.