



Austrian Institute of Construction Engineering  
 Schenkenstrasse 4 | T+43 1 533 65 50  
 1010 Vienna | Austria | F+43 1 533 64 23  
 www.oib.or.at | mail@oib.or.at



## European Technical Assessment

**ETA-10/0406**  
**of 28.06.2018**

General part

**Technical Assessment Body issuing the European Technical Assessment**

Österreichisches Institut für Bautechnik (OIB)  
 Austrian Institute of Construction Engineering

**Trade name of the construction product**

Hilti Firestop Intumescent Sealant CFS-IS

**Product family to which the construction product belongs**

Fire Stopping and Fire Sealing Products:  
 Penetration Seals

**Manufacturer**

Hilti AG  
 Feldkircherstrasse 100  
 9494 Schaan  
 LIECHTENSTEIN

**Manufacturing plant**

Hilti production plant 4a

**This European Technical Assessment contains**

22 pages including Annexes A to C which form an integral part of this assessment.

**This European Technical Assessment is issued in accordance with Regulation (EU) No 305/2011, on the basis of**

European Assessment Document  
 EAD 350454-00-1104 "Fire stopping and fire sealing products – Penetration seals"

**This European Technical Assessment replaces**

European Technical Approval ETA-10/0406 with validity from 28.06.13 to 27.06.2018



Specific parts

**1 Technical description of the product**

“Hilti Firestop Intumescent Sealant CFS-IS” is a 1-component product used as a cable and/or pipe penetration seal.

Sealant	Characteristics
Hilti Firestop Intumescent Sealant CFS-IS	Water-based 1-component acrylic sealant with intumescent fire protection additives and binder according to Annex C.1 of the ETA.

Additional component	Characteristics
Mineral wool backfilling material	Loose mineral wool products suitable as backfilling material according to Annex B.2 of the ETA.

**2 Specification of the intended use(s) in accordance with the applicable European Assessment Document (hereinafter EAD)**

**2.1 Intended use**

“Hilti Firestop Intumescent Sealant CFS-IS” is intended to be used as a mixed penetration seal to temporarily or permanently reinstate the fire resistance performance of flexible wall constructions, rigid wall constructions or rigid floor constructions where they have been provided with apertures which are penetrated by various cables, conduits, metal pipes and / or plastic pipes. For more details see Annex C of the ETA.

The maximum opening size of the penetration seal is w x h = 150 mm x 150 mm or circular openings of an equivalent maximum area in walls and floors.

“Hilti Firestop Intumescent Sealant CFS-IS” can be installed only in the types of separating elements as specified in the following table.

Separating element	Construction
Flexible walls	<ul style="list-style-type: none"> <li>&gt; Steel studs or timber studs lined on both faces with minimum 2 layers of boards (minimum thickness 12,5 mm) according to EN 520 type F</li> <li>&gt; For steel stud walls the space between lining must not be completely filled with insulation material, especially in the adjacent area of the penetration seal</li> <li>&gt; For timber studs walls there must be a minimum distance of 100 mm of the penetration seal to any timber stud. The cavity between the penetration seal and stud has to be closed with minimum of 100 mm of insulation with classification A1 or A2 according to EN 13501-1</li> <li>&gt; Minimum thickness 100 mm</li> </ul>
Rigid walls	<ul style="list-style-type: none"> <li>&gt; Aerated concrete, concrete, masonry</li> <li>&gt; Minimum density 550 kg/m<sup>3</sup></li> <li>&gt; Minimum thickness 100 mm</li> <li>&gt; The rigid wall shall be classified in accordance with EN 13501-2 for the required fire resistance period</li> </ul>

Rigid floors	<ul style="list-style-type: none"><li>&gt; Aerated concrete, concrete</li><li>&gt; Minimum density 650 kg/m<sup>3</sup></li><li>&gt; Minimum thickness 150 mm</li><li>&gt; The rigid floor shall be classified in accordance with EN 13501-2 for the required fire resistance period</li></ul>
--------------	--

The first support of the cables / conduits shall be located at maximum 250 mm away from both faces of wall constructions and maximum 250 mm from the upper face of floor constructions.

Other parts or service support constructions shall not penetrate the penetration seal. This European Technical Assessment does not cover sandwich panel constructions.

## 2.2 Use condition

“Hilti Firestop Intumescent Sealant CFS-IS” is intended for use at temperatures below 0°C, but with no exposure to rain nor UV and can therefore – according to EAD 350454-00-1104 clause 2.2.9.3.1 – be categorized as Type Y<sub>2</sub>. Since the requirements for Type Y<sub>2</sub> are met, also the requirements for Type Z<sub>1</sub> and Z<sub>2</sub> are fulfilled.

## 2.3 Working life

The provisions made in this European Technical Assessment are based on an assumed working life of “Hilti Firestop Intumescent Sealant CFS-IS” of 10 years, provided the conditions laid down in the technical literature of the manufacturer relating to packaging, transport, storage, installation, use and repair are met.

The indications given on the intended working life cannot be interpreted as a guarantee given by the producer or the Technical Assessment Body, but are to be regarded only as a means for selecting the appropriate product in relation to the expected economically reasonable working life of the works.

The real working life might be, in normal use conditions, considerably longer without major degradation affecting the Basic requirements for construction works.

## 2.4 General assumptions

### 2.4.1 It is assumed that

- > damages to the penetration seal are repaired accordingly,
- > the installation of the penetration seal does not affect the stability of the adjacent building element – even in case of fire,
- > the lintel or floor above the penetration seal is designed structurally and in terms of fire protection such that no additional mechanical load (other than its own weight) is imposed on the penetration seal,
- > the thermal movement in the pipe work will be accommodated in such way that it does not impose a load on the penetration seal,
- > the installations are fixed to the adjacent building element in accordance with the relevant regulations in such a way that, in case of fire, no additional mechanical load is imposed to the penetration seal,
- > the support of the installations is maintained for the required period of fire resistance and
- > pneumatic dispatch systems, compressed air systems, etc. are switched off by additional means in case of fire.

**2.5 Manufacturing**

The European Technical Assessment is issued for the product on the basis of agreed data / information, deposited with the Österreichisches Institut für Bautechnik, which identifies the product that has been assessed and judged. Changes to the product or production process, which could result in this deposited data / information being incorrect, should be notified to the Österreichisches Institut für Bautechnik before the changes are introduced.

The Österreichisches Institut für Bautechnik will decide whether or not such changes affect the European Technical Assessment and consequently the validity of the CE marking on the basis of the European Technical Assessment and if so whether further assessment or alterations to the European Technical Assessment, shall be necessary.

**3 Performance of the product and references to the methods used for its assessment**

Basic requirements for construction works	Essential characteristic	Method of verification	Performance
<b>BWR 2</b>	Reaction to fire	EN 13501-1:2007+A1:2009	Clause 3.1.1 of the ETA
	Resistance to fire	EN 13501-2:2007+A1:2009	Clause 3.1.2 and Annex C.1 to C.4 of the ETA
<b>BWR 3</b>	Air permeability	EN 1026:2000	Clause 3.2.1 of the ETA
	Water permeability	No performance assessed	
	Content, emission and/or release of dangerous substances	No performance assessed	
<b>BWR 4</b>	Mechanical resistance and stability	No performance assessed	
	Resistance to impact / movement	No performance assessed	
	Adhesion	No performance assessed	
	Durability	EAD 350454-00-1104 clause 2.2.9	Clause 3.3.4 of the ETA
<b>BWR 5</b>	Airborne sound insulation	EN ISO 10140-1 and EN ISO 10140-2, EN ISO 717-1	Clause 3.4.1 of the ETA
<b>BWR 6</b>	Thermal properties	No performance assessed	
	Water vapour permeability	No performance assessed	

**3.1 Safety in case of fire (BWR 2)**

**3.1.1 Reaction to fire**

“Hilti Firestop Intumescent Sealant CFS-IS” was assessed according to EAD 350454-00-1104 clause 2.2.1 and classified according to EN 13501-1:2007+A1:2009.

Component	Class according to EN 13501-1:2007+A1:2009
Hilti Firestop Intumescent Sealant CFS-IS	E

3.1.2 Resistance to fire

“Hilti Firestop Intumescent Sealant CFS-IS” was tested according to EAD 350454-00-1104 clause 2.2.2, EN 1363-1 and EN 1366-3:2009.

Based upon the gained test results and the field of application specified within EN 1363-1 and EN 1366-3:2009 the penetration seal “Hilti Firestop Intumescent Sealant CFS-IS” has been classified according to EN 13501-2:2007+A1:2009. The individual fire resistance classes are listed in Annex C.1 to C.4 of the ETA.

The maximum fire resistance class of the penetration seal in vertical or horizontal separating element depends on the fire resistance class of the penetrating elements. The fire resistance class of the penetration seal is reduced to the fire resistance class of the penetrating element with the lowest fire resistance classification.

The classifications are not valid for sandwich panel constructions.

**3.2 Hygiene, health and the environment (BWR 3)**

3.2.1 Air permeability

The air permeability of “Hilti Firestop Intumescent Sealant CFS-IS” with a thickness of 50 mm and a Ø 94 mm was tested as blank penetration seal according to EAD 350454-00-1104 clause 2.2.3 under application of the test principles of EN 1026. Any other components were not included in these tests.

Pressure [Pa]	50	250
q/A air [m <sup>3</sup> /(h·m <sup>2</sup> )]	impermeable	impermeable

3.2.2 Water permeability

No performance assessed.

3.2.3 Content, emission and/or release of dangerous substances

No performance assessed.

**3.3 Safety and accessibility in use (BWR 4)**

3.3.1 Mechanical resistance and stability

No performance assessed.

3.3.2 Resistance to impact / movement

No performance assessed.

Provisions shall be taken to prevent a person from stepping onto a horizontal penetration seal or falling against a vertical penetration seal (e.g. by covering with a wire mesh).

3.3.3 Adhesion

No performance assessed.

3.3.4 Durability

All components of “Hilti Firestop Intumescent Sealant CFS-IS” fulfil the requirements for the intended use category.

“Hilti Firestop Intumescent Sealant CFS-IS” is therefore appropriate for use at temperatures below 0°C, but with no exposure to rain nor UV and can therefore – according to EAD 350454-00-1104 clause 2.2.9.3.1 – be categorized as Type Y<sub>2</sub>. Since the requirements for Type Y<sub>2</sub> are met, also the requirements for Type Z<sub>1</sub> and Z<sub>2</sub> are fulfilled.

### 3.4 Protection against noise (BWR 5)

#### 3.4.1 Airborne sound insulation

The airborne sound insulation of “Hilti Firestop Intumescent Sealant CFS-IS” was tested according to EN ISO 10140-1 and EN ISO 10140-2. The rating of the sound insulation properties has been calculated in accordance with EN ISO 717-1.

The acoustic testing was performed in a joint configuration, 1200 mm long, 25 mm wide and 100 mm deep. The joint was backfilled with mineral wool and closed on both sides with Intumescent “Hilti Firestop Intumescent Sealant CFS-IS” to a thickness of 25 mm. The joint was constructed in accordance with EN 10140-1:2016, Annex J. “Hilti Firestop Intumescent Sealant CFS-IS” was tested as a blank seal without services.

The reached values for the airborne sound insulation in accordance with EN ISO 717-1:2013 are as follows:

Component	R (C; Ctr)
Hilti Firestop Intumescent Sealant CFS-IS	64 (-2; -5)

### 3.5 Energy economy and heat retention (BWR 6)

#### 3.5.1 Thermal properties

No performance assessed.

#### 3.5.2 Water vapour permeability

No performance assessed.

## 4 Assessment and verification of constancy of performance (hereinafter AVCP) system applied, with reference to its legal base

According to the Decision 1999/454/EC<sup>1</sup>, amended by Decision 2001/596/EC<sup>2</sup> of the European Commission the system(s) of assessment and verification of constancy of performance (see Annex V of Regulation (EU) No 305/2011) is given in the following table.

Product(s)	Intended use(s)	Level(s) or class(es) (resistance to fire)	System of assessment and verification of constancy of performance
Fire Stopping and Fire Sealing Products	for fire compartmentation and/or fire protection or fire performance	any	1

<sup>1</sup> Official Journal of the European Communities no. L 178, 14.7.1999, p. 52

<sup>2</sup> Official Journal of the European Communities no. L 209, 2.8.2001, p. 33

In addition, according to the Decision 1999/454/EC, amended by Decision 2001/596/EC of the European Commission the system(s) of assessment and verification of constancy of performance, with regard to reaction to fire, is given in the following table.

Product(s)	Intended use(s)	Level(s) or class(es) (reaction to fire)	System of assessment and verification of constancy of performance
Fire Stopping and Fire Sealing Products	For uses subject to regulations on reaction to fire	A1*, A2*, B*, C*	1
		A1**, A2**, B**, C**, D, E	3
		(A1 to E)***, F	4
<p>* Products/materials for which a clearly identifiable stage in the production process results in an improvement of the reaction to fire classification (e.g. an addition of fire retardants or a limiting of organic material)</p> <p>** Products/materials not covered by footnote (*)</p> <p>*** Products/materials that do not require to be tested for reaction to fire (e.g. products/materials of class A1 according to Commission Decision 96/603/EC, as amended)</p>			

**5 Technical details necessary for the implementation of the AVCP system, as provided for in the applicable EAD**

Technical details necessary for the implementation of the AVCP system are laid down in the control plan deposited with the Technical Assessment Body Österreichisches Institut für Bautechnik.

The notified product certification body shall visit the factory at least twice a year for surveillance of the manufacturer.

Issued in Vienna on 28.06.2018  
by Österreichisches Institut für Bautechnik

The original document is signed by:

Rainer Mikulits  
Managing Director

## ANNEX A REFERENCE DOCUMENTS and LIST OF ABBREVIATIONS

### A.1 References to standards mentioned in the ETA

EN 1026	Windows and doors – Air permeability – Test method
EN 1363-1	Fire resistance tests – Part 1: General Requirements
EN 1366-3	Fire resistance tests for service installations - Part 3: Penetration seals
EN 13501-1	Fire classification of construction products and building elements – Part 1: Classification using test data from reaction to fire tests
EN 13501-2	Fire classification of construction products and building elements – Part 2: Classification using test data from fire resistance tests
EN ISO 10140-1	Acoustics; Acoustics - Laboratory measurement of sound insulation of building elements - Part 1: Application rules for specific products
EN ISO 10140-2	Acoustics; Acoustics - Laboratory measurement of sound insulation of building elements - Part 2: Measurement of airborne sound insulation
EN ISO 717-1	Acoustics - Rating of sound insulation in buildings and of building elements - Part 1: Airborne sound insulation

### A.2 Other reference documents

EOTA TR 024	Characterisation, Aspects of Durability and Factory Production Control for Reactive Materials, Components and Products
-------------	--

### A.3 Abbreviations used in drawings

Abbreviation	Description
A	Hilti Firestop Intumescent Sealant CFS-IS
B	Backfilling material
E	Building element (wall, floor)
h	Height/length of penetration seal
L <sub>A</sub>	Length of additional “Hilti Firestop Intumescent Sealant CFS-IS” in front of the wall/floor
S <sub>1</sub> , S <sub>2</sub>	Distances
t <sub>A</sub> , t <sub>1A</sub>	Thickness (depth) of penetration seal
t <sub>2A</sub>	Thickness of additional “Hilti Firestop Intumescent Sealant CFS-IS” in front of the wall/floor
t <sub>B</sub>	Thickness (depth) of backfilling material
t <sub>E</sub>	Thickness of the building element
w	Width of penetration seal

## ANNEX B

### DESCRIPTION OF PRODUCT(S) & PRODUCT LITERATURE

#### B.1 Hilti Firestop Intumescent Sealant CFS-IS

“Hilti Firestop Intumescent Sealant CFS-IS” is a 1-component product and is composed essentially of filling substances, intumescent components and binder (acrylic).

A detailed specification of the product is contained in document “Identification / Product Specification relating to the European technical assessment ETA-10/0406, Hilti Firestop Intumescent Sealant CFS-IS” which is a non-public part of this ETA.

The Control Plan is defined in document “Control Plan relating to the European Technical Assessment ETA-10/0406, Hilti Firestop Intumescent Sealant CFS-IS”, which is a non-public part of this ETA.

#### B.2 Mineral Wool

Loose mineral wool products suitable for being used as backfilling material

Product	Manufacturer	Specification
Heralan LS	Knauf Insulation GmbH	Product data sheet of manufacturer
Isover loose wool SL	Saint-Gobain ISOVER	Product data sheet of manufacturer
Isover Universal-Stopfwole	Saint-Gobain ISOVER	Product data sheet of manufacturer
Rockwool RL	Rockwool	Product data sheet of manufacturer
Paroc Pro Loose Wool	Paroc OY AB	Product data sheet of manufacturer

#### B.3 Technical product literature

Technical data sheet and instructions for use “Hilti Firestop Intumescent Sealant CFS-IS”.

## ANNEX C

### RESISTANCE TO FIRE CLASSIFICATION OF PENETRATION SEALS MADE OF "HILTI FIRESTOP INTUMESCENT SEALANT CFS-IS"

#### C.1 General Information

##### C.1.1 Wall/floor constructions

a) Flexible wall:

The wall must have a minimum thickness of 100 mm and comprise timber or steel studs lined on both faces with minimum 2 layers of 12.5 mm thick boards according to EN 520 type F.

For timber stud walls there must be a minimum distance of 100 mm of the seal to any stud and the cavity between stud and seal must be closed and a minimum of 50 mm insulation of Class A1 or A2 (in accordance with EN 13501-1) in the cavity between stud and seal is necessary.

b) Rigid wall:

The wall must have a minimum thickness of 110 mm and comprise concrete, aerated concrete or masonry, with a minimum density of 550 kg/m<sup>3</sup>.

c) Rigid floor:

The floor must have a minimum thickness of 150 mm and comprise aerated concrete or concrete with a minimum density of 650 kg/m<sup>3</sup>.

The first support of the cables / conduits shall be located at maximum 250 mm away from both faces of wall constructions and maximum 250 mm from the upper face of floor constructions.

The walls / floors must be classified in accordance with EN 13501-2 for the required fire resistance period or fulfil the requirements of the relevant Eurocode. This ETA does not cover use of the product as a penetration seal in sandwich panel constructions.

#### C.2 Flexible walls according to Annex C.1.1 of the ETA

##### Penetration seal:

Hilti Firestop Intumescent Sealant CFS-IS (A) on both sides, thickness (t<sub>A</sub>) 25 mm, mineral wool (B) tightly compressed as backfilling material, thickness (t<sub>B</sub>) ≥ 50 mm (gap filled completely).

For suitable products for mineral wool backfilling material see Annex B of the ETA.

Maximum seal size: 150 x 150 mm or circular openings of equivalent area.

Minimum distances (mm):

Cables to edge of seal	S <sub>1</sub> = 0
Cable to other cables/services	S <sub>2</sub> = 0
Tied cable bundle to seal edge	S <sub>1</sub> = 10
Tied cable bundle to other services	S <sub>2</sub> = 0
Small conduits/tubes to edge of seal	S <sub>1</sub> = 10
Small conduits/tubes to other services	S <sub>2</sub> = 0
Conduits 16 ≤ Ø ≤ 32 mm to edge of seal	S <sub>1</sub> = 10
Conduits 16 ≤ Ø ≤ 32 mm to other services	S <sub>2</sub> = 10

electronic copy



<b>C.2.3 Conduits</b>	<b>Classification</b>
Small steel conduits and tubes, diameter $\leq 16$ mm, arranged linear, with or without cables	EI 120-C/U
Small plastic conduits and tubes, diameter $\leq 16$ mm, arranged linear, with or without cables	EI 120-U/C
Plastic conduits, diameter $16 \leq \varnothing \leq 32$ mm, wall thickness 1 – 3 mm, arranged linear or in a cluster, with or without cables	EI 120-U/C

<b>C.2.4 Single conduit and pipe penetrations</b>
The width of the annular sealant is between 5 and 25 mm

– PVC pipes (EN 1451-1), not insulated	<b>Classification</b>
diameter $\geq 16$ to 20 mm, wall thickness 1,8 to 2,2 mm	EI 120 U/U
diameter 32 mm, wall thickness 1,8 to 3,6 mm	EI 60 U/U E 120 U/U
diameter $\geq 32$ to 40 mm, wall thickness 1,9 to 3,6 mm	EI 90 U/U
diameter $\geq 40$ to 50 mm, wall thickness 1,8 to 3,7 mm	EI 90 U/C E120 U/C

– Geberit Mepla, Aluminium composite pipes PE-XD/Al/PE-HD, not or local insulated with Armaflex AF pipe insulation	<b>Classification</b>
diameter $\geq 16$ to 50 mm, wall thickness 2,25 to 4,0 mm	EI 60 U/C E 120 U/C
diameter $\geq 16$ to 50 mm, wall thickness 2,25 to 4,0 mm; insulation Armaflex AF1 to AF4, thickness 8 - 21 mm, length 250 mm	EI 90 U/C

– Geberit Silent, PP pipes PP-C/PP-MD/PP-C, not insulated	<b>Classification</b>
diameter $\geq 32$ to 40 mm, wall thickness 2,0 mm	EI 90 U/U
diameter 50 mm, wall thickness 2,0 mm	EI 90 U/C E120 U/C

– Kekelit Kelox, Aluminium composite pipes PE-XB/Al/PE-XB, not or local insulated with Armaflex AF pipe insulation	<b>Classification</b>
diameter $\geq 16$ to 50 mm, wall thickness 2,0 to 4,0 mm	EI 90 U/C E120 U/C
diameter $\geq 16$ to 50 mm, wall thickness 2,0 to 4,0 mm; insulation Armaflex AF1 to AF4, thickness 8 - 21 mm, length 250 mm	EI 120 U/C

– LK Schweden, Aluminium composite pipes PE-RT/Al/PE-RT, not or local insulated with Armaflex AF pipe insulation	<b>Classification</b>
diameter $\geq 16$ to 40 mm, wall thickness 2,0 to 3,5 mm	EI 60 U/C E90 U/C
diameter $\geq 16$ to 40 mm, wall thickness 2,0 to 3,5 mm; insulation Armaflex AF1 to AF4, thickness 8 - 21 mm, length 250 mm	EI 90 U/C
– LK Schweden, PEXa pipes, not insulated	<b>Classification</b>
diameter $\geq 16$ to 32 mm, wall thickness 2,2 to 4,0 mm	EI 90 U/C
– LK Schweden, Aluminium composite pipes PE-RT/Al/PE-RT, inside PVC corrugated pipe	<b>Classification</b>
diameter $\geq 16$ to 32 mm, wall thickness 2,0 to 4,0 mm; PVC pipe diameter 25 to 44 mm, thickness 1,0 mm	EI 90 U/C E120 U/C
– LK Schweden, PEXa pipes, inside PVC corrugated pipe	<b>Classification</b>
diameter $\geq 16$ to 25 mm, wall thickness 2,2 to 3,5 mm; PVC pipe diameter 25 to 34 mm, thickness 1,0 mm	EI120 U/C
diameter $\geq 16$ to 40 mm, wall thickness 2,0 to 3,5 mm; insulation Armaflex AF1 to AF4, thickness 8 - 21 mm, length 250 mm	EI 90 U/C
– PP Life Master 3, PP pipes PP-CO/PP-MV/PP-CO (EN 1451-1), not insulated	<b>Classification</b>
diameter $\geq 32$ to 40 mm, wall thickness 1,8 mm	EI 120 U/U
diameter 50 mm, wall thickness 1,8 mm	EI 90 U/C
– Uponor Uni Pipe Plus, Aluminium composite pipes PE-RT/Al/PE-RT, not or local insulated with Armaflex AF pipe insulation	<b>Classification</b>
diameter $\geq 16$ to 32 mm, wall thickness 2,0 to 3,5 mm	EI 60 U/C E120 U/C
diameter $\geq 16$ to 32 mm, wall thickness 2,0 to 3,5 mm; insulation Armaflex AF1 to AF4, thickness 8 – 19,5 mm, length 250 mm	EI 90 U/C E120 U/C
<b>C.2.5 Single conduit and pipe penetrations.</b>	
The width of the annular sealant is between 5 and 25 mm. The thickness of the wall is minimum 110 mm. Flexible wall as described in Annex C.1.1 of the ETA.	
– Copper pipes, locally insulated with Rockwool RS 800	<b>Classification</b>
Copper pipes, diameter $\geq 10$ to 42 mm, wall thickness 1,0/1,2 to 14,2 mm, with Rockwool RS 800 pipe insulation, thickness 20 mm, length $\geq 700$ mm	EI 120 C/U
Copper pipes, diameter $\geq 42$ to 89 mm, wall thickness 1,0/2,0 to 14,2 mm, with Rockwool RS 800 pipe insulation, thickness 40 mm, length $\geq 925$ mm	EI120 C/U

– Copper pipes, continuously insulated with Armaflex AF Insulation	<b>Classification</b>
Copper pipes, diameter $\geq 10$ to 42 mm, wall thickness 1,0/1,2 to 14,2 mm, with continuous Armaflex AF1 – AF4 pipe insulation, thickness 7,5 to 20,5 mm	EI 120 C/U
Copper pipes, diameter $\geq 42$ to 89 mm, wall thickness 1,0/2,0 to 14,2 mm, with continuous Armaflex AF2 – AF4 pipe insulation, thickness 14,5 to 22,5 mm	EI60 C/U E120 C/U
– Rigid, flexible and pliable plastic conduits	<b>Classification</b>
Rigid, flexible and pliable plastic conduit up to $\varnothing$ 40 mm with or without cables and conduit bundles up to $\varnothing$ 80 mm; Flexible PVC conduit – Dietzel VRM- Turbo 7 class: 2221 – with or without cables; Flexible PO conduit – Pipe Life FB-E-LF / class: 22322 – with or without cables	EI120 U/U
Rigid, flexible and pliable plastic conduit up to $\varnothing$ 40 mm with or without cables and conduit bundles up to $\varnothing$ 80 mm	EI120 U/U

electronic copy

**C.3 Rigid wall constructions according to Annex C.1.1 of the ETA**

**Penetration seal:**

Seal type 1: Hilti Firestop Intumescent Sealant CFS-IS (A) on both sides, thickness ( $t_A, t_{1A}$ ) 25 mm, mineral wool (B) tightly compressed as backfilling material, thickness ( $t_B$ )  $\geq 100$  mm (gap filled completely).

Seal type 2: additional Hilti Firestop Intumescent Sealant CFS-IS ( $t_{2A} \geq 10$  mm,  $L_A \geq 50$  mm) on both sides.

Seal type 3: additional Hilti Firestop Intumescent Sealant CFS-IS ( $t_{2A} \geq 10$  mm,  $L_A \geq 100$  mm) on both sides.

For suitable products for mineral wool backfilling material see Annex B of the ETA.

Maximum seal size: 150 x 150 mm or circular openings of equivalent area.

Minimum distances (mm):

Cables to edge of seal	$S_1 = 0$
Cable to other cables/services	$S_2 = 0$
Tied cable bundle to seal edge	$S_1 = 10$
Tied cable bundle to other services	$S_2 = 0$
Small conduits/tubes to edge of seal	$S_1 = 10$
Small conduits/tubes to other services	$S_2 = 0$
Conduits $16 \leq \varnothing \leq 32$ mm to edge of seal	$S_1 = 10$
Conduits $16 \leq \varnothing \leq 32$ mm to other services	$S_2 = 10$

**Construction details:**

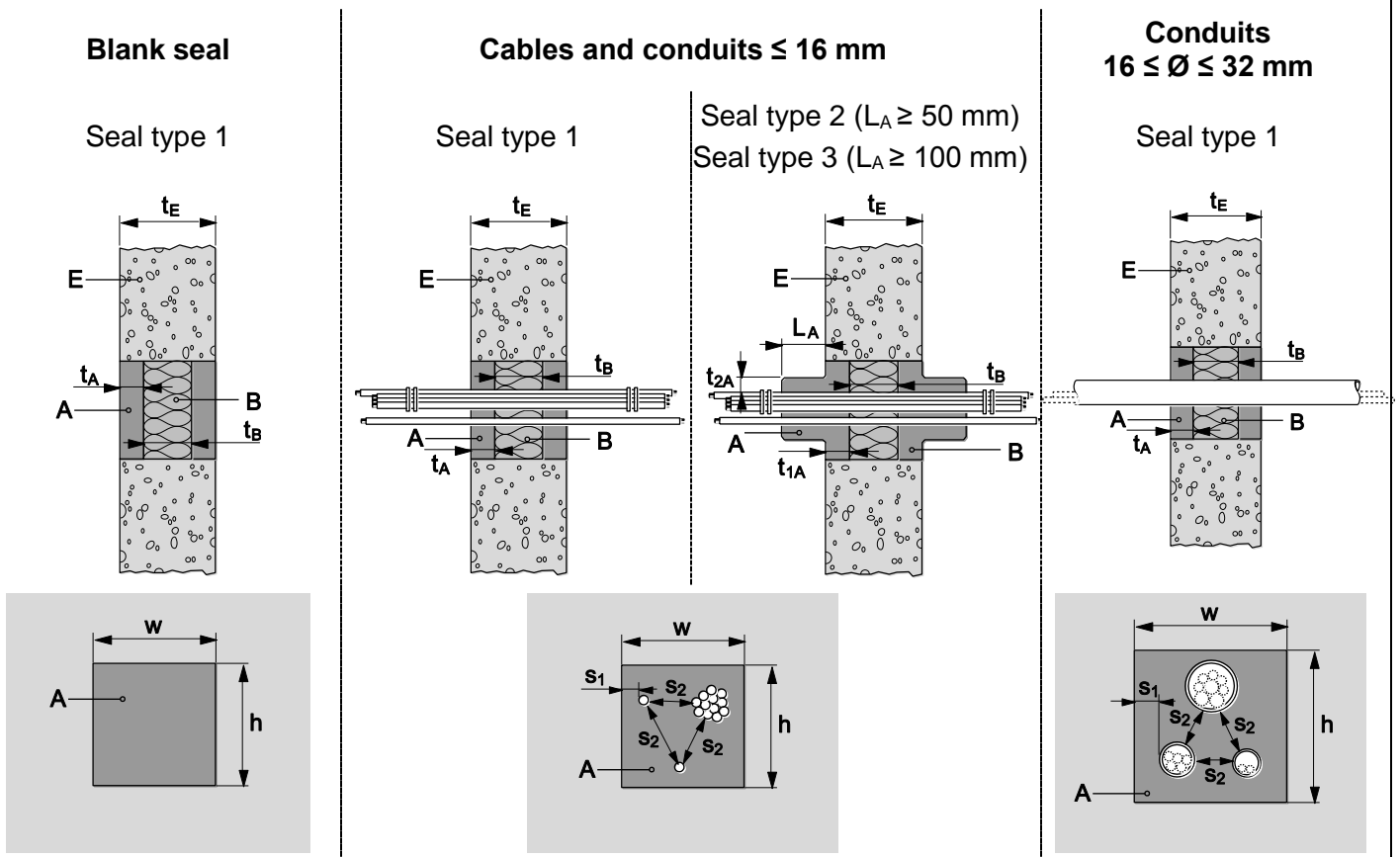

For abbreviations see the related text and Annex A of the ETA.



electronic copy

<b>C.3.4 Conduits</b>			
Small steel conduits and tubes, diameter $\leq 16$ mm, arranged linear, with or without cables	EI 120-C/U	EI 120-C/U	EI 120-C/U
Small plastic conduits and tubes, diameter $\leq 16$ mm, arranged linear, with or without cables	EI 120-U/C	EI 120-U/C	EI 120-U/C
Plastic conduits, diameter $16 \leq \varnothing \leq 32$ mm, wall thickness 1 – 3 mm, arranged linear or in a cluster, with or without cables	EI 120-U/C	EI 120-U/C	EI 120-U/C

<b>C.3.5 Single pipe penetration</b>			
The opening has maximum dimensions $\varnothing 100$ mm. The wall must comprise concrete, aerated concrete or masonry, with a minimum density of $650 \text{ kg/m}^3$			
PVC pipes (EN 1451-1), not insulated $\varnothing \geq 32$ to 50 mm, wall thickness 2,1/2,2 to 6,4 mm	EI180 U/U	---	---

**C.4 Rigid floor constructions according to Annex C.1.1 of the ETA**

<b>Penetration seal:</b>	
Seal type 4: Hilti Firestop Intumescent Sealant CFS-IS (A) on top side, thickness ( $t_A$ ) 25 mm, mineral wool (B) tightly compressed as backfilling material, thickness ( $t_B$ ) $\geq 125$ mm	
Seal type 5: additional Hilti Firestop Intumescent Sealant CFS-IS ( $t_{2A} \geq 10$ mm, $L_A \geq 50$ mm) on top only	
Seal type 6: additional Hilti Firestop Intumescent Sealant CFS-IS ( $t_{2A} \geq 10$ mm, $L_A \geq 100$ mm) on top only	
Seal type 7: additional Hilti Firestop Intumescent Sealant CFS-IS ( $t_{2A} \geq 10$ mm, $L_A \geq 50$ mm) on both sides.	
Seal type 8: additional Hilti Firestop Intumescent Sealant CFS-IS ( $t_{2A} \geq 10$ mm, $L_A \geq 100$ mm) on both sides.	
For suitable products for mineral wool backfilling material see Annex B of the ETA.	
Maximum seal size: 150 x 150 mm or circular openings of equivalent area.	
Minimum distances (mm):	
Cables to edge of seal	$s_1 = 0$
Cable to other cables/services	$s_2 = 0$
Tied cable bundle to seal edge	$s_1 = 10$
Tied cable bundle to other services	$s_2 = 0$
Small conduits/tubes to edge of seal	$s_1 = 20$
Small conduits/tubes to other services	$s_2 = 0$
Conduits $16 \leq \varnothing \leq 32$ mm to edge of seal	$s_1 = 10$
Conduits $16 \leq \varnothing \leq 32$ mm to other services	$s_2 = 10$

**Construction details:**

**Blank seal**

Seal type 4

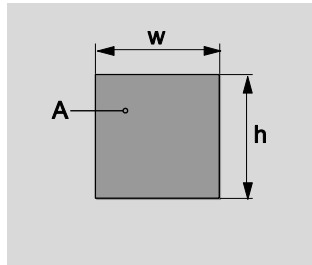
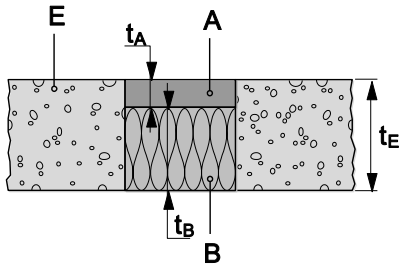

**Conduits  $16 \leq \varnothing \leq 32$  mm**

Seal type 7 ( $L_A \geq 50$  mm)

Seal type 8 ( $L_A \geq 100$  mm)

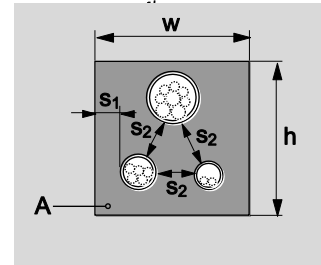
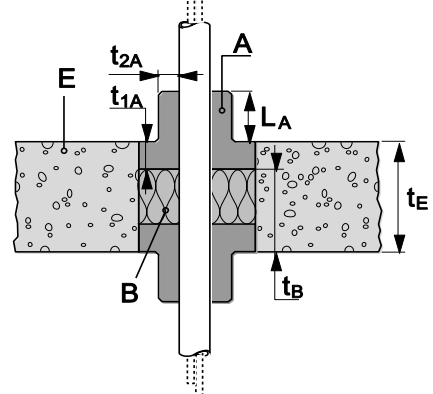

**Cables and conduits  $\leq 16$  mm**

Seal type 4

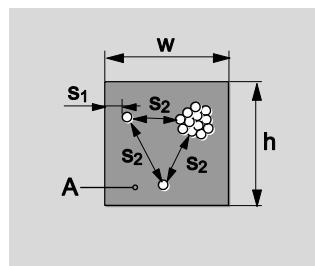
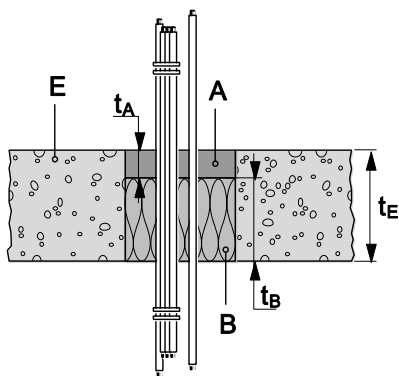

Seal type 5 ( $L_A \geq 50$  mm)

Seal type 6 ( $L_A \geq 100$  mm)

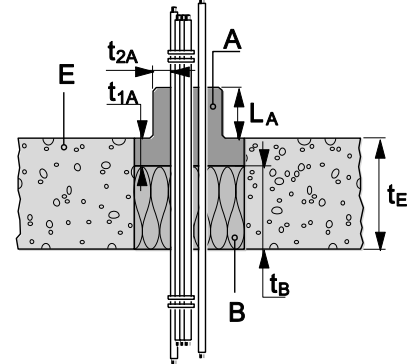

For abbreviations see the related text and Annex A of the ETA.

<b>C.4.1 Blank seal</b>	
<p>*) If cables are added later only cables with a diameter &lt; 21 mm may be added if the required classification is EI 120.</p> <p>If the seal is used in a floor with a requirement of EI 90 or less all types of cables according to Annex C.4.2, and C.4.3 of the ETA and tied cable bundles according to Annex C.4.2 of the ETA and small conduits/tubes according to Annex C.4.4 and C.4.5 of the ETA may be added later on.</p> <p>If Hilti Firestop Intumescent Sealant CFS-IS is additionally used with <math>L_A \geq 50</math> mm / <math>t_{2A} \geq 10</math> mm on top and bottom (seal type 7), conduits according to Annex C.4.4 of the ETA may be added for a requirement of EI 120.</p> <p>If Hilti Firestop Intumescent Sealant CFS-IS is additionally used with <math>L_A \geq 100</math> mm / <math>t_{2A} \geq 10</math> mm on top only (seal type 6), all cables according to Annex C.4.2 of the ETA may be added for a requirement of EI 120.</p>	<b>Classification</b>  EI 120 *)

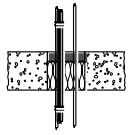
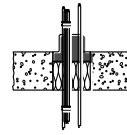
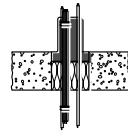
<b>C.4.2 Cables</b>			
<p>All sheathed cable types currently and commonly used in building practice in Europe (e.g. power, control, signal, telecommunication, data, optical fibre cables) with a diameter of:</p>	<b>Classification</b>		
	Seal type 4	Seal type 5	Seal type 6
			
Maximum $\varnothing$ 21 mm	EI 120	EI 120	EI 120
$21 \leq \varnothing \leq 80$ mm	EI 90 E120	EI 90 E120	EI 120
Tied cable bundle <sup>5</sup> , maximum diameter of 100 mm, maximum diameter of single cable 21 mm	EI 90 E120	EI 120	EI 120

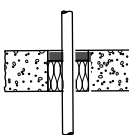
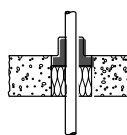
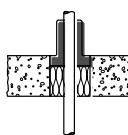
<b>C.4.3 Conduits</b>			
	<b>Classification</b>		
	Seal type 4	Seal type 5	Seal type 6
			
Small steel conduits and tubes, diameter $\leq 16$ mm, arranged linear, with or without cables	EI 90-C/U	EI 120-C/U	EI 120-C/U
Small plastic conduits and tubes, diameter $\leq 16$ mm, arranged linear, with or without cables	EI 90-U/C	EI 120-U/C	EI 120-U/C

<sup>5</sup> Several cables running in the same direction and bound closely together by mechanical means



– LK Schweden, PEXa pipes, not insulated	<b>Classification</b>
diameter $\geq$ 16 to 32 mm, wall thickness 2,2 to 4,0 mm	EI 120 U/C
– LK Schweden, Aluminium composite pipes PE-RT/Al/PE-RT, inside PVC corrugated pipe	<b>Classification</b>
diameter $\geq$ 16 to 32 mm, wall thickness 2,0 to 4,0 mm; PVC pipe diameter 25 to 44 mm, thickness 1,0 mm	EI 120 U/C
– LK Schweden, PEXa pipes, inside PVC corrugated pipe	<b>Classification</b>
diameter $\geq$ 16 to 25 mm, wall thickness 2,2 to 3,5 mm; PVC pipe diameter 25 to 34 mm, thickness 1,0 mm	EI 120 U/C
– PP Life Master 3, PP pipes PP-CO/PP-MV/PP-CO (EN 1451-1), not insulated	<b>Classification</b>
diameter $\geq$ 32 to 40 mm, wall thickness 1,8 mm	EI 90 U/U
diameter 50 mm, wall thickness 1,8 mm	EI 120 U/C
– Uponor Uni Pipe Plus, Aluminium composite pipes PE-RT/Al/PE-RT, not or local insulated with Armaflex AF pipe insulation	<b>Classification</b>
diameter $\geq$ 16 to 32 mm, wall thickness 2,0 to 3,5 mm	EI 120 U/C
diameter $\geq$ 16 to 32 mm, wall thickness 2,0 to 3,5 mm; insulation Armaflex AF1 to AF4, thickness 8 – 19,5 mm, length 250 mm	EI 120 U/C
– Copper pipes, locally insulated with Rockwool RS 800	<b>Classification</b>
Copper pipes, diameter $\geq$ 10 to 42 mm, wall thickness 1,0/1,2 to 14,2 mm, with Rockwool RS 800 pipe insulation, thickness 20 mm, length $\geq$ 700 mm	EI 120 C/U
Copper pipes, diameter $\geq$ 42 to 89 mm, wall thickness 1,0/2,0 to 14,2 mm, with Rockwool RS 800 pipe insulation, thickness 40 mm, length $\geq$ 925 mm	EI 120 C/U
– Copper pipes, continuously insulated with Armaflex AF pipe insulation	<b>Classification</b>
Copper pipes, diameter $\geq$ 10 to 42 mm, wall thickness 1,0/1,2 to 14,2 mm, with continuous Armaflex AF1 – AF4 pipe insulation, thickness 7,5 to 20,5 mm	EI 120 C/U
Copper pipes, diameter $\geq$ 42 to 89 mm, wall thickness 1,2/2,0 to 14,2 mm, with continuous Armaflex AF2 – AF4 pipe insulation, thickness 14,5 to 22,5 mm	EI 60 C/U E 120 C/U
– Rigid, flexible and pliable plastic conduits	<b>Classification</b>
Rigid, flexible and pliable plastic conduit up to $\varnothing$ 40 mm with or without cables and conduit bundles up to $\varnothing$ 80 mm	EI 120 U/U