

ÖSTERREICHISCHES INSTITUT FÜR BAUTECHNIK

A-1010 Vienna, Schenkenstrasse 4
Tel.: + 4 3 (0) 1 - 5 3 3 6 5 5 0
Fax: + 4 3 (0) 1 - 5 3 3 6 4 2 3
E-mail: mail@oib.or.at

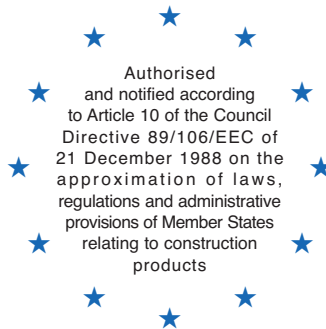

Member of EOTA

European technical approval

ETA-10/0403

(English language translation, the original version is in German language)

Handelsbezeichnung:
Trade name:

Hilti Firestop Collar CFS-C

Zulassungsinhaber:
Holder of approval:

**Hilti AG
Feldkircherstrasse 100
9494 Schaan
Liechtenstein**

Zulassungsgegenstand
und Verwendungszweck:

Abschottungen

*Generic type and use of
construction product:*

Penetration seals

Geltungsdauer vom:
Validity from:
bis:
to:

22.02.2011

21.02.2016

Herstellwerk:
Manufacturing plant:

Hilti Werk 5a and Hilti Werk 5b

Diese Europäische
technische Zulassung umfasst:
*This European technical approval
contains:*

23 Seiten inklusive **3** Anhängen

23 pages including **3** Annexes



European Organisation for Technical Approvals
Europäische Organisation für Technische Zulassungen
Organisation Européenne pour l'Agrément technique

I LEGAL BASES AND GENERAL CONDITIONS

- 1 This European technical approval is issued by Österreichisches Institut für Bautechnik in accordance with:
 - Council Directive 89/106/EEC of 21 December 1988 on the approximation of laws, regulations and administrative provisions of Member States relating to construction products¹ modified by Council Directive 93/68/EEC² and Regulation (EC) N° 1882/2003 of the European Parliament and of the Council³;
 - Bauproduktengesetz. LGBl. V Nr. 33/1994;
 - Common Procedural Rules for Requesting, Preparing and the Granting of European technical approvals set out in the Annex to Commission Decision 94/23/EC⁴;
 - Guideline for European technical approval of Fire Stopping and Fire Sealing Products: Part 2: Penetration Seals.
- 2 The Österreichisches Institut für Bautechnik is authorized to check whether the provisions of this European technical approval are met. Checking may take place in the manufacturing plant(s). Nevertheless, the responsibility for the conformity of the products to the European technical approval and for their fitness for the intended use remains with the holder of the European technical approval.
- 3 This European technical approval is not to be transferred to manufacturers or agents of manufacturers other than those indicated on page 1, or manufacturing plants other than those indicated on page 1 of this European technical approval.
- 4 This European technical approval may be withdrawn by Österreichisches Institut für Bautechnik, in particular pursuant to information by the Commission according to Article 5(1) of Council Directive 89/106/EEC.
- 5 Reproduction of this European technical approval including transmission by electronic means shall be in full. However, partial reproduction can be made with the written consent of Österreichisches Institut für Bautechnik. In this case partial reproduction has to be designated as such. Texts and drawings of advertising brochures shall not contradict or misuse the European technical approval.
- 6 The European technical approval is issued by the approval body in English. This version corresponds fully to the version circulated in EOTA. Translations into other languages have to be designated as such.

¹ Official Journal of the European Communities N° L 40, 11.2.1989, p. 12

² Official Journal of the European Communities N° L 220, 30.8.1993, p. 1

³ Official Journal of the European Union N° L 284, 31.10.2003, p.1

⁴ Official Journal of the European Communities N° L 17, 20.1.1994, p. 34

II SPECIFIC CONDITIONS OF THE EUROPEAN TECHNICAL APPROVAL

1 Definition of product(s) and intended use

1.1 Definition of the construction product

Hilti Firestop Collar CFS-C is a pipe closure device installed around plastic pipes to form a penetration seal to reinstate the fire resistance performance of wall and floor constructions, where they have been provided with apertures for the penetration of services.

Type of penetration seal system: Pipe closure device - collar (see ETAG 026-2, clause 1.1, table 1-1). Hilti Firestop Collar CFS-C consists of a steel housing, an intumescent inlay and fastening hooks.

Hilti Firestop Collar CFS-C is supplied in several sizes – see table below. The collar is installed underneath floors or on both sides of a wall and fixed by hooks and metal anchors.

Collar size	For pipes with nominal outside diameters (mm)	Recommended opening size (mm)	Required number of fastening hooks
CFS-C 50/1.5"	50	62	2
CFS-C 63/2"	63	77	2
CFS-C 75/2.5"	75	82	3
CFS-C 90/3"	90	112	3
CFS-C 110/4"	110	122	4
CFS-C 125/5"	125	142	4
CFS-C 160/6"	160	182	4

For the purpose of smoke and draft stop, air or water tightness and airborne sound insulation, the gap between opening edge and pipe or collar has to be sealed off by gypsum plaster, cementitious mortar or a construction sealant, the latter optionally in combination with mineral wool as backfilling material, considering the detailed prescriptions given in Annexes B and C.

In case sound decoupling between the pipe and the wall/floor is required, but sound decoupling means around the pipe are missing it is recommended to use Hilti Firestop Acrylic Sealant CFS-S ACR (ETA-10/0292) as annular gap seal. If gypsum plaster or cementitious mortar is intended to be used it is recommended to install a PE foam strip around the pipe over the entire wall or floor thickness for sound decoupling of the pipe. For further details see Annexes B and C.

In case air permeability data according to 2.3 or airborne sound insulation data according to 2.9.1 are intended to be used, Hilti Firestop Acrylic Sealant CFS-S ACR must be used to seal off the annular gap between pipe and opening edge.

For a description of the installation procedure see 4.2.

1.2 Intended Use and Use Category

1.2.1 Intended Use

The intended use of Hilti Firestop Collar CFS-C is to reinstate the fire resistance performance of flexible wall constructions, rigid wall constructions and rigid floor constructions where they are penetrated by plastic pipes.

- (1) The specific elements of construction that Hilti Firestop Collar CFS-C may be used to provide a penetration seal in, are as follows:

Flexible walls: The wall must have a minimum thickness of 100 mm and comprise timber or steel studs lined on both faces with minimum 2 layers of 12,5 mm thick boards. For timber stud walls there must be a minimum distance of 100 mm of the seal to any stud and the cavity between stud and seal must be closed and minimum 100 mm insulation of Class A1 or A2 (in accordance with EN 13501-1) in the cavity between stud and seal.

Rigid walls: The wall must have a minimum thickness as given in Annex C and comprise concrete, aerated concrete or masonry, with a minimum density of 650 kg/m³.

Rigid floors: The floor must have a minimum thickness as given in Annex C and comprise concrete with a minimum density of 2400 kg/m³ (floor type A) or 550 kg/m³ (floor type B) respectively.

The supporting construction must be classified in accordance with EN 13501-2 for the required fire resistance period.

This ETA does not cover use of this product as a penetration seal in sandwich panel constructions.

- (2) Hilti Firestop Collar CFS-C may be used to provide a penetration seal with the following specific services, single only:

PVC pipes: for details on diameters, wall thickness and pipe standards see Annex C.

PE pipes: for details on diameters, wall thickness and pipe standards see Annex C.

- (3) Apertures for the penetration of pipes require separation of minimum 200 mm.

- (4) Pipes shall be supported at maximum 300 mm away from both faces of wall constructions and maximum 200 mm from the upper face of floor constructions.

The provisions made in this European technical approval are based on an assumed working life of the Hilti Firestop Collar CFS-C of 10 years, provided that the conditions laid down in sections 4.2/5.1/5.2 for the packaging / transport / storage / installation / use / repair are met. The indications given on the working life cannot be interpreted as a guarantee given by the producer, but are to be regarded only as a means for choosing the right products in relation to the expected economically reasonable working life of the works.

1.2.2 Use Category

The use category of Hilti Firestop Collar CFS-C is Type Z₂.

Type Z₂: Products for penetration seals intended for uses at internal conditions with humidity classes other than Z₁⁵, excluding temperatures below 0°C.

⁵

Use category Z₁ uses apply for internal humidity class 5 in accordance with EN ISO 13788

2 Characteristics of the product and methods of verification

The identification tests and the assessment of the fitness for use according to the Essential Requirements were carried out in compliance with the “ETA Guidance no. 026-Part 2” concerning Penetration Seals – edition January 2008 (called ETAG 026-2 in this ETA).

ETAG Clause No.	ETA clause No.	Characteristic	Assessment of characteristic
		Mechanical resistance and stability	Not relevant
		Safety in case of fire	
2.4.1	2.1	Reaction to fire	Class F according to EN 13501-1:2007
2.4.2	2.2	Resistance to fire	See clause 2.2
		Hygiene, Health and the Environment	
2.4.3	2.3	Air permeability	See clause 2.3
2.4.4	2.4	Water permeability	See clause 2.4
2.4.5	2.5	Dangerous substances	No performance determined
		Safety in use	
2.4.6	2.6	Mechanical resistance and stability	No performance determined
2.4.7	2.7	Resistance to impact/movement	No performance determined
2.4.8	2.8	Adhesion	No performance determined
		Protection against noise	
2.4.9	2.9	Airborne sound insulation	See clause 2.9
		Energy, Economy and Heat Retention	
2.4.10	2.10	Thermal properties	No performance determined
2.4.11	2.11	Water vapour permeability	No performance determined
		General aspects relating to fitness for use	
2.4.12	2.12	Durability and serviceability	Z ₂

2.1 Reaction to fire

The inlay of the Hilti Firestop Collar CFS-C is classified 'F' in accordance with EN 13501-1.

The reaction to fire classification for Hilti Firestop Acrylic Sealant CFS-S ACR is class 'D - s1 d0' in accordance with EN 13501-1.

2.2 Resistance to fire

Hilti Firestop Collar CFS-C has been tested in accordance with EN 1366-3:2004 and EN 1366-3:2009, installed within apertures in installed in flexible walls (drywalls), rigid walls (aerated concrete blocks) and high density and low density concrete floors.

For details of classification and plastic pipes covered see Annex C.

The seals may only be penetrated by the services listed in Annex C. Other parts or support constructions must not penetrate the seal.

For details of suitable wall and floor constructions see 1.2.1 and Annex C.

Note: The supporting construction must be classified in accordance with EN 13501-2 for the required fire resistance period.

General: The following conditions apply to seals within any of the above constructions:

The service support construction must be fixed to the building element containing the penetration seal or a suitable adjacent building element, on both sides of the penetration in such a manner that in the case of fire, no additional load is imposed on the seal. Furthermore it is assumed that this support is maintained on the unexposed side, for the required period of fire resistance.

Specific considerations:

- Pipes must be perpendicular to the seal surface.
- It is assumed that compressed air systems are switched off by other means in the case of fire.
- The function of the pipe seal in case of pneumatic dispatch systems, pressurised air systems etc. is guaranteed only when the systems are shut off in case of fire.
- The approval does not address any risks associated with leakage of dangerous liquids or gases caused by failure of the pipe(s) in case of fire.
- The durability assessment does not take account of the possible effect of substances permeating through the pipe on the penetration seal.
- The classifications relate to U/C (capped outside the furnace/uncapped inside). For further information refer to national regulations.
- The risk of spread of fire downwards caused by burning material, which drips through a pipe downwards to floors below, cannot be assessed with tests according to EN 1366-3 and is therefore not part of the assessment of this ETA.

2.3 Air permeability

Air tightness for a single penetration of a plastic pipe, fire stopped with Hilti Firestop Collar CFS-C can only be achieved when the annular gap is sealed with a sealant, e.g. using Hilti Firestop Acrylic Sealant CFS-S ACR.

For Hilti Firestop Acrylic Sealant CFS-S ACR the gas permeability regarding the gases air, nitrogen (N₂), carbon dioxide (CO₂) and CH₄ (methane) has been tested according to the principles of EN 1026 for an Acrylic Sealant thickness of 10 mm. The following flow rates per area (q/A) have been achieved for the given air pressure differences (Δp). The flow rate index indicates the type of gas:

Gas permeability of Hilti Firestop Acrylic Sealant CFS-S ACR

Δp [Pa]	q/A air [m ³ /(h·m ²)]	q/A N ₂ [m ³ /(h·m ²)]	q/A CO ₂ [m ³ /(h·m ²)]	q/A CH ₄ [m ³ /(h·m ²)]
50	≤ 1,9E-06	≤ 1,1E-06	≤ 6,4E-05	≤ 4,3E-05
250	≤ 9,7E-06	≤ 5,5E-06	≤ 3,2E-04	≤ 2,1E-04

The declared values refer to a body of pure Hilti Firestop Acrylic Sealant CFS-S ACR without any penetrating installation.

For annular gaps sealed with cementitious mortar or gypsum plaster no performance has been determined.

2.4 Water permeability

Water tightness for a single penetration of a plastic pipe, fire stopped with Hilti Firestop Collar CFS-C can only be achieved when the annular gap is sealed with a sealant, e.g. using Hilti Firestop Acrylic Sealant CFS-S ACR.

The water permeability of Hilti Firestop Acrylic Sealant CFS-S ACR has been tested according to the principles given in Annex C of ETAG 026-2. The specimen consisted of 2 mm Hilti Firestop Acrylic Sealant CFS-S ACR (dry film thickness) on stone wool. Test result: Water tight to 1000 mm head of water or 9806 Pa.

For annular gaps sealed with cementitious mortar or gypsum plaster no performance has been determined.

2.5 Dangerous substances

According to the manufacturer's declaration, the product specification has been compared with the list of dangerous substances of the European Commission to verify that that it does not contain such substances above the acceptable limits.

A written declaration in this respect was submitted by the ETA-holder.

In addition to the specific clauses relating to dangerous substances contained in this ETA, there may be other requirements applicable to the products falling within its scope (e.g. transposed European legislation and national laws, regulations and administrative provisions). In order to meet the provisions of the Construction Product Directive, these requirements need also to be complied with, when and where they apply..

2.6 Mechanical resistance and stability

No performance determined.

2.7 Resistance to impact/movement

No performance determined.

2.8 Adhesion

The fixing of the collars (number of hooks, material and dimensions of fasteners) must be done according to the provisions given in 4.2 and Annex C.

2.9 Airborne sound insulation

Airborne sound insulation for a single penetration of a plastic pipe, fire stopped with Hilti Firestop Collar CFS-C can only be achieved when the annular gap is sealed. It has to be noted that the values given in 2.9.1 are only valid if the annular gap is sealed using mineral wool as backfilling material (which is not necessary in all cases for fire resistance – see Annex C).

2.9.1 Annular gap seal with Hilti Firestop Acrylic Sealant CFS-S ACR

Test reports from noise reduction according to EN ISO 140-3, EN ISO 20140-10 and EN ISO 717-1 have been provided.

The acoustic tests were performed in a flexible wall and in a rigid wall. Hilti Firestop Acrylic Sealant CFS-S ACR was tested as seal around a steel pipe, filled with concrete. The seal was 50 mm wide (annular gap) and consisted of 160 mm mineral wool, covered by 20 mm Hilti Firestop Acrylic Sealant CFS-S ACR on both sides (rigid wall) and 50 mm mineral wool covered by 25 mm on both sides (flexible wall). This set up simulates a linear joint as well as a single penetration seal. The area of Hilti Firestop Acrylic Sealant CFS-S ACR was 0,0236 m². The acoustic characteristics of the walls itself have not been measured. According to these tests reports the single number ratings are:

Flexible wall:

Weighted element-normalized level difference: $D_{n,w} = 60$ dB

From this $D_{n,w}$ the weighted sound reduction index calculates to: $R_w = 53$ dB

Structure of the flexible wall: 2 x 12,5 mm plasterboard on both sides of a 50 mm metal stud frame. The void was filled with a 50 mm mineral wool slab.

Rigid wall:

Weighted element-normalized level difference: $D_{n,w} = 58$ dB

From this $D_{n,w}$ the weighted sound reduction index calculates to: $R_w = 51$ dB

Structure of the rigid wall: 200 mm thick concrete wall with a density of 2000 kg/m³ which was plastered on both sides.

It should be noticed that both above mentioned results apply to the total wall construction of the size $S = 1,25$ m x 1,50 m (= 1,88 m²), i.e. the given wall with 0,0236 m² Hilti Firestop Acrylic Sealant CFS-S ACR.

2.9.2 Annular gap seal with cementitious mortar

Test reports from noise reduction according to EN ISO 140-3, EN ISO 20140-10 and EN ISO 717-1 have been provided.

The acoustic tests were performed in a rigid wall. Results are also applicable of floors of minimum the same thickness. The cementitious mortar was tested as a 500 x 600 x 175 mm block in a wall of 1,25 x 1,50 m. The area of mortar was 0,30 m². The acoustic characteristics of the walls itself have not been measured. According to these tests reports the single number ratings are:

Weighted element-normalized level difference: $D_{n,w} = 59$ dB

From this $D_{n,w}$ the weighted sound reduction index calculates to: $R_w = 52$ dB

Structure of the rigid wall: 175 mm thick blockwork wall with a density of 2000 kg/m³ which was plastered on both sides.

It should be noticed that both above mentioned results apply to the total wall construction of the size $S = 1,25 \text{ m} \times 1,50 \text{ m} (= 1,88 \text{ m}^2)$, i.e. the given wall with $0,30 \text{ m}^2$ cementitious mortar. For smaller mortar seals in a wall of the same size the values will be higher.

2.9.3 Annular gap seal with gypsum plaster

No performance determined.

2.10 Thermal properties

No performance determined.

2.11 Water vapour permeability

No performance determined.

2.12 Durability

Hilti Firestop Collar CFS-C has been tested in accordance with ETAG 026-2 for the Z_2 use category specified in ETAG 026-2 and the results of the test have demonstrated suitability for penetration seals intended for use at internal conditions with humidity classes other than Z_1^6 , excluding below 0°C .

3 Evaluation of Conformity and CE marking

3.1 Attestation of Conformity system

According to the decision 1999/454/EC of the European Commission⁷ the system 1 of attestation of conformity applies.

This system of attestation of conformity is defined as follows:

System 1: Certification of the conformity of the product by a notified certification body on the basis of:

(a) Tasks for the manufacturer:

- (1) factory production control;
- (2) further testing of samples taken at the factory by the manufacturer in accordance with a prescribed test plan;

(b) Tasks for the notified body

- (3) initial type-testing of the product;
- (4) initial inspection of factory and of factory production control;
- (5) continuous surveillance, assessment and approval of factory production control.

3.2 Responsibilities

3.2.1 Tasks of the Manufacturer

3.2.1.1 Factory production control

The manufacturer shall exercise permanent internal control of production. All the elements, requirements and provisions adopted by the manufacturer shall be documented in a systematic manner in the form of written policies and procedures, including records of results performed. This production control system shall insure that the product is in conformity with this European technical approval.

⁶ Use category Z_1 uses apply for internal humidity class 5 in accordance with EN ISO 13788

⁷ Official Journal of the European Communities N° L 178, 14.7.1999, p. 52

The manufacturer shall draw up and keep up-to-date documents defining the factory production control that applies. The documentation to be carried out by the manufacturer and the applicable procedures shall be appropriate to the product and manufacturing process. The factory production control shall ensure the conformity of the product to an appropriate level. This involves:

- a) the preparation of documented procedures and instructions relating to factory production control operations.
- b) the effective implementation of these procedures and instructions.
- c) the recording of these procedures and their results.
- d) the use of these results to correct any deviations, repair the effects of such deviations, treat any resulting instances of non-conformity and, if necessary, revise the factory production control to rectify the cause of non-conformity.
- e) a procedure to ensure that both the approval Body and the Notified (Certification) Bodies are advised before any significant change to the product, its components or manufacturing process, is made.
- f) a procedure to ensure that personnel involved in the production processes and the quality control procedures are qualified and adequately trained to carry out their required tasks.
- g) that all testing and measuring equipment is maintained and up to date calibration records are documented.
- h) maintenance of records to ensure every batch produced is clearly labelled with the batch number, which allows traceability to its production to be identified.

The manufacturer may only use components stated in the technical documentation of this European technical approval.

For the components which the ETA-holder does not manufacture by himself, he shall make sure that factory production control carried out by the other manufacturers gives the guaranty of the components compliance with the European technical approval.

The factory production control of the ETA holder and the provisions taken by the ETA-holder for components not produced by himself shall be in accordance with the control plan⁸ relating to this European technical approval which is part of the technical documentation of this European technical approval. The "Control Plan" is laid down in the context of the factory production control system operated by the manufacturer and deposited at the Österreichisches Institut für Bautechnik.

The results of factory production control shall be recorded and evaluated in accordance with the provisions of the control plan.

Additional information

The manufacturer shall provide a technical data sheet and an installation instruction with the following minimum information:

technical data sheet:

- Field of application:
 - Building elements for which the penetration seal is suitable, type and properties of the building elements like minimum thickness, density, and - in case of lightweight constructions – the construction requirements.

⁸

The control plan is a confidential part of the European Technical Approval and only handed over to the Notified Body or Bodies involved in the procedure of conformity.

- Services for which the penetration seal is suitable, type and properties of the services like material, diameter, thickness etc. in case of pipes including insulation materials; necessary/allowed supports/fixings
- Limits in size, minimum dimensions etc. of the penetration seal
- Construction of the penetration seal including the necessary components and additional products (e.g. backfilling material) with clear indication whether they are generic or specific.

Installation instruction:

- Steps to be followed

Procedure in case of retrofitting

.3.2.1.2 Other tasks of manufacturer

The manufacturer shall, on the basis of a contract, involve a body (bodies) which is (are) approved for the tasks referred to in section 3.1 in the field of penetration seals in order to undertake the actions laid down in section 3.3. For this purpose, the "control plan" referred to in sections 3.2.1.1 and 3.2.2 shall be handed over by the manufacturer to the approved body and notified body/bodies involved.

The manufacturer shall make a declaration of conformity, stating that the construction product is in conformity with the provisions of this European technical approval.

3.2.2 Tasks of Notified Bodies

The Notified Body (Bodies) shall perform the

- initial type-testing of the product (for system1),
The results of the tests performed as part of the assessment for the European technical approval may be used unless there are changes in the production line or plant. In such cases, the necessary initial type testing has to be agreed between the Österreichisches Institut für Bautechnik and the Notified Bodies involved.
- initial inspection of factory and of factory production control,
The Notified Body (Bodies) shall ascertain that, in accordance with the control plan, the factory (in particular the employees and the equipment) and the factory production control are suitable to ensure continuous and orderly manufacturing of the components according to the specifications mentioned in clause 2 of this ETA.
- continuous surveillance, assessment and approval of factory production control,
The Notified Body (Bodies) shall visit the factory at once a year for surveillance of this manufacturer having a FPC system complying with a quality management system covering the manufacturing of the approval product components. It has to be verified that the system of factory production control and the specified automated manufacturing process are maintained taking into account the control plan.

These tasks shall be performed in accordance with the provisions laid down in the control plan of this European technical approval.

The Notified Body (Bodies) shall retain the essential points of its (their) actions referred to above and state the results obtained and conclusions drawn in a written report.

The Notified Body involved by the manufacturer shall issue an EC certificate of conformity of the product stating the conformity with the provisions of this European technical approval.

In cases where the provisions of the European technical approval and its control plan are no longer fulfilled the certification body shall withdraw the certificate of conformity and inform the Österreichisches Institut für Bautechnik without delay.

3.3 CE marking

The CE marking shall be affixed on the product itself, on a label attached to it, on its packaging or on the commercial documents accompanying the components of the product. The letters „CE“ shall be followed by the identification number of the Notified Body involved and be accompanied by the following additional information:

- the name or identifying mark and address of the ETA holder,
- the last two digits of the year in which the CE marking was affixed,
- the number of the EC certificate of conformity for the product,
- the number of the European technical approval,
- the number of the ETAG (ETAG N° 026 part 2)
- the designation of the product (trade name)
- the use category in accordance with the ETA section 1 and 2
- “see ETA-10/0403 for other relevant characteristics (e.g. resistance to fire)”

4 Assumptions under which the fitness of the product(s) for the intended use was favourably assessed

4.1 Manufacturing

The European technical approval is issued for the product on the basis of agreed data/information, deposited with Österreichisches Institut für Bautechnik, which identifies the product that has been assessed and judged. Changes to the product or production process, which could result in this deposited data/information being incorrect, should be notified to Österreichisches Institut für Bautechnik before the changes are introduced. Österreichisches Institut für Bautechnik will decide whether or not such changes affect the ETA and consequently the validity of the CE marking on the basis of the ETA and if so whether further assessment or alterations to the ETA, shall be necessary.

4.2 Installation

The ETA is issued under the assumption that the installation of the approval product will be done in accordance with the manufacturer’s technical literature.

1. Seal the opening:

The aperture around the pipe is filled with gypsum plaster (flexible walls) or cementitious mortar (concrete walls/floors) over the full thickness of the wall/floor or alternatively sealed with minimum 25 mm thick Hilti Firestop Acrylic Sealant CFS-S ACR on both sides. Backfilling with stone wool may be omitted in case of small annular gaps and classifications \leq EI 120.

In case of missing sound decoupling means around the pipe it is recommended to use Hilti Firestop Acrylic Sealant CFS-S ACR as annular gap seal. If gypsum plaster or cementitious mortar is intended to be used it is recommended to install a PE foam strip around the pipe over the entire wall or floor thickness for sound decoupling of the pipe.

2. Clean the plastic pipe. Remove all plaster/mortar or dust from the pipe in the area where the Firestop collar is to be installed.
3. Close the Hilti Firestop Collar: Place the Hilti Firestop Collar around the plastic pipe and apply firm pressure by hand until it latches with a "click" sound. No tools, pins or screws are necessary. The Hilti Firestop Collar can be re-opened by pushing down the engaged "tongue" with a screwdriver while pulling the Hilti Firestop Collar apart.
4. Attach fastening hooks/tabs: The fastening hooks can be attached to various points of the metal housing. The hooks must be positioned as symmetrically as possible. The required number of fastening hooks is indicated on the packaging.

5. Fasten the Hilti Firestop Collar:
 - a) Attach fastening hooks/tabs on the metal housing.
 - b) Mark the fastening points on the wall/floor.
 - c) Fasten the Hilti Firestop Collar, using recommended metal anchors/fasteners, e. g. Hilti DBZ, Hilti HUS, Hilti HSA for rigid walls and floors or threaded rod, nuts, washers in flexible walls. These are defined in the respective test reports and approvals.
 - d) If required by national prescriptions mark the penetration seal with an identification plate containing the required information. In such a case fasten the identification plate in a visible position next to the seal.
6. Repeat installation on the other side of the wall

5 Indications to the manufacturer

5.1 Packaging, transport and storage

In the accompanying document and/or on the packaging the manufacturer shall give information as to transport and storage.

At least the following shall be indicated: storing temperature, type of storage, maximum duration of storage and required data related to minimum temperature for transport and storage.

Storage: Store in a dry place protected from moisture

Storage temperature: -5° up to max. +50°C

5.2 Use, maintenance, repair

The Hilti Firestop Collar CFS-C should be installed and used as described earlier in this document.

The assessment of the fitness for use is based on the assumption that damage, for example caused by accidental impact, is repaired. The relevant manufacturer instructions shall be followed.

On behalf of Österreichisches Institut für Bautechnik

Rainer Mikulits
Managing Director

ANNEX A

REFERENCE DOCUMENTS and LIST OF ABBREVIATIONS

A.1 References to standards mentioned in the ETA:

EN 1026	Windows and doors – Air permeability – Test method
EN 1366-3:2009	Fire resistance tests for service installations - Part 3: Penetration seals
EN 13501-1	Fire classification of construction products and building elements – Part 1: Classification using test data from reaction to fire tests
EN 13501-2	Fire classification of construction products and building elements – Part 2: Classification using test data from fire resistance tests
EN ISO 140-3	Acoustics – Measurement of sound insulation in buildings and of building elements – Part 3: Laboratory measurements of airborne sound insulation of building elements
EN ISO 20140-10	Acoustics – Measurements of sound insulation in buildings and of building elements – Part 10: Laboratory measurement of airborne sound insulation of small building elements
EN ISO 717-1	Acoustics – Rating of sound insulation of buildings and of building elements – Part 1: Airborne sound insulation

A.2 Abbreviations used in drawings

Abbreviation	Description
A ₁	Hilti Firestop Collar CFS-C
A ₂	Annular gap seal
A ₃	Annular gap seal with gypsum plaster or cementitious mortar
B	Backfilling material (mineral wool)
C	Plastic Pipe
C ₁	Sound decoupling strip
d _C	Pipe diameter (nominal outside diameter)
E	Building element (wall, floor)
F	Fixing of the collar
s ₁	Minimum distance between single penetration seals
t _{A2}	Thickness of Hilti Firestop Acrylic Sealant CFS-S ACR
t _C	Pipe wall thickness
t _E	Thickness of the building element

ANNEX B

DESCRIPTION OF PRODUCT(S) & PRODUCT LITERATURE

B.1 Hilti Firestop Collar CFS-C

The housing of the collar consists of electrolytically galvanized steel, the inlay consists of an intumescent strip and a foam strip that fills the space between inlay and the pipe to avoid passage of smoke. A detailed specification of the product is contained in document "Identification / Product Specification relating to the European technical approval ETA – 10/0403 - Hilti Firestop Collar CFS-C" which is a non-public part of this ETA.

The Control Plan is defined in document "Control Plan relating to the European technical approval ETA-10/0403 - Hilti Firestop Collar CFS-C" which is a non-public part of this ETA.

technical product literature:

- technical Data Sheet Hilti Firestop Collar CFS-C (including the use of additional components according to B.2 to B.6).

B.2 Hilti Firestop Acrylic Sealant CFS-S ACR

Hilti Firestop Acrylic Sealant CFS-S ACR is a 1-component acrylic based sealant. A detailed specification of the product is contained in document "Identification / Product Specification relating to the European technical approval ETA-10/0292 and ETA-10/0389 - Hilti Firestop Acrylic Sealant CFS-S ACR" which is a non-public part of the referenced ETAs.

The Control Plan is defined in document "Control Plan relating to the European technical approval ETA-10/0292 and ETA-10/0389 - Hilti Firestop Acrylic Sealant CFS-S ACR" which is a non-public part of the referenced ETAs.

B.3 Gypsum plaster

Any gypsum plaster suitable for use with flexible wall constructions or the intended type of rigid walls or floors may be used.

B.4 Cementitious mortar

Any cementitious mortar suitable for use with the intended type of rigid walls or floors may be used.

B.5 Mineral wool

Loose mineral wool products suitable for being used as backfilling material of Hilti Firestop Acrylic Sealant CFS-S ACR

Product	Manufacturer	Specification
Heralan LS	Knauf Insulation GmbH	Product data sheet of Knauf
Isover loose wool SL	Saint-Gobain ISOVER	Product data sheet of Isover
Isover Universal-Stopfwolle	Saint-Gobain ISOVER	Product data sheet of Isover
Rockwool RL	Rockwool	Product data sheet of Rockwool
Paroc Pro Loose Wool	Paroc OY AB	Product data sheet of Paroc

B.6 Sound decoupling strip

Any sound decoupling strip based on PE (foam) may be used with a maximum thickness as given in Annex C.

ANNEX C

RESISTANCE TO FIRE CLASSIFICATION OF PENETRATION SEALS MADE FROM HILTI FIRESTOP COLLAR CFS-C

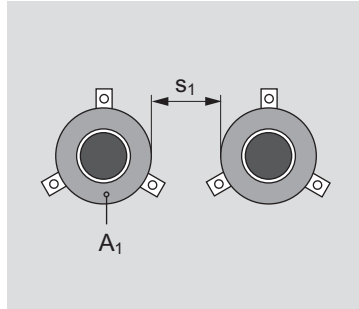
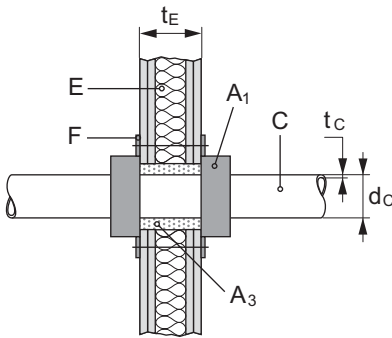
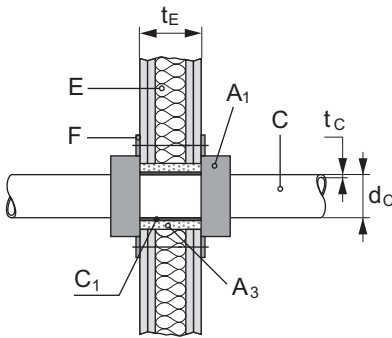
C.1 Flexible and rigid walls according to 1.2.1, minimum wall thickness 100 mm	
<p>Penetration seal: Single penetration; Hilti Firestop Collar CFS-C on both sides (A_1), annular gap filled either with gypsum plaster (A_3) over the entire thickness of the wall or with Hilti Firestop Acrylic Sealant CFS-S ACR (A_2) on both sides with a depth of minimum 25 mm from the surface of the wall. In case of a rigid wall cementitious mortar may be used as an alternative to gypsum plaster. The sealant may be backfilled with mineral wool. Minimum distance between collars / annular gap (s_1): 200 mm Width of annular gap: The opening diameter should not be larger than the collar outside diameter to allow a safe fixing of the collar to the wall. Collars fixed by hooks (F) and threaded rods M8 through the wall fixed with nuts on both sides of the wall. In high density rigid walls alternatively metal anchors with minimum \varnothing 8 mm may be used. For minimum number of hooks see table below. Sound decoupling: maximum thickness 5 mm (C_1 - used in combination with gypsum plaster or mortar).</p>	
	
Annular gap seal	
Gypsum plaster (A_3)	
Gypsum plaster (A_3) together with sound decoupling (C_1)	

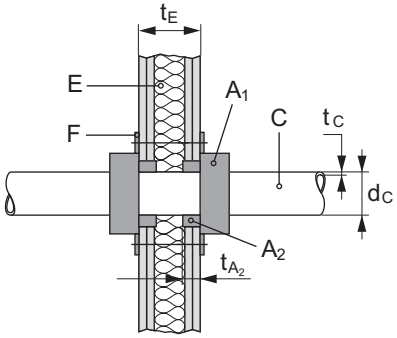
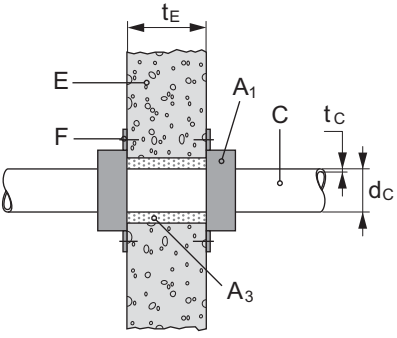
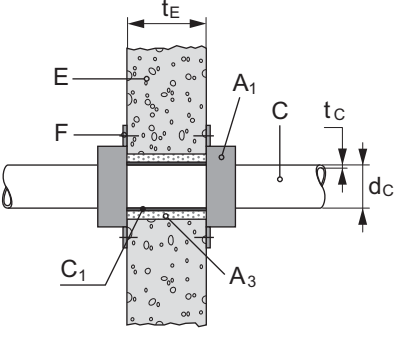
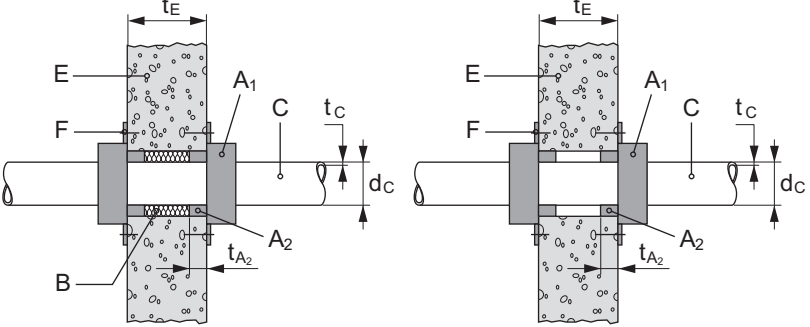
<p>Hilti Firestop Acrylic Sealant CFS-S ACR (A₂)</p>	
<p>Gypsum plaster or cementitious mortar (A₃)</p>	
<p>Gypsum plaster or cementitious mortar (A₃) together with sound decoupling (C₁)</p>	
<p>Hilti Firestop Acrylic Sealant CFS-S ACR (A₂)</p>	

Penetrating services				
C.1.1 PVC-U pipes according to EN ISO 15493, EN ISO 1452 and DIN 8061/8062				
Pipe diameter d_c (mm)	Pipe wall thickness t_c (mm)	Collar size (A_1)	No. of hooks	Classification
50	2,4 – 5,6	CFS-C 50/1.5"	2	EI 120-U/C
63	3,0 – 4,7	CFS-C 63/2"	2	EI 120-U/C
75	2,2 – 3,6	CFS-C 75/2.5"	3	EI 120-U/C
90	2,7 – 4,3	CFS-C 90/3"	3	EI 120-U/C
110	1,8 – 2,2	CFS-C 110/4"	4	EI 90-U/C
110	2,2 – 8,1	CFS-C 110/4"	4	EI 120-U/C
125	3,7 – 6,0	CFS-C 125/5"	4	EI 90-U/C
125	6,0	CFS-C 125/5"	4	EI 120-U/C
160	2,5 – 11,8	CFS-C 160/6"	4	EI 120-U/C
The results are also valid for PVC-C pipes according to EN 1566-1 ⁹ and PVC-U pipes according to EN 1329-1 ¹⁰ and EN 1453-1 ¹⁰ .				
C.1.2 PE pipes according to EN ISO 15494 and DIN 8074/8075				
Pipe diameter d_c (mm)	Pipe wall thickness t_c (mm)	Collar size (A_1)	No. of hooks	Classification
50	2,9 – 4,6	CFS-C 50/1.5"	2	EI 120-U/C
63	1,8 – 5,8	CFS-C 63/2"	2	EI 120-U/C
75	1,9 – 6,8	CFS-C 75/2.5"	3	EI 120-U/C
90	2,2 – 8,2	CFS-C 90/3"	3	EI 120-U/C
110	2,7 – 10,0	CFS-C 110/4"	4	EI 120-U/C
125	3,1 – 7,1	CFS-C 125/5"	4	EI 120-U/C
160	2,5 – 11,8	CFS-C 160/6"	4	EI 120-U/C
C.1.3 PE pipes according to EN 1519-1¹¹				
Pipe diameter d_c (mm)	Pipe wall thickness t_c (mm)	Collar size (A_1)	No. of hooks	Classification
50	3,0	CFS-C 50/1.5"	2	EI 120-U/C
63	3,0	CFS-C 63/2"	2	EI 120-U/C
75	3,0	CFS-C 75/2.5"	3	EI 120-U/C
90	3,5	CFS-C 90/3"	3	EI 120-U/C
110	4,2	CFS-C 110/4"	4	EI 120-U/C
125	4,8	CFS-C 125/5"	4	EI 120-U/C
160	6,2	CFS-C 160/6"	4	EI 120-U/C
The results are also valid for PE pipes according to EN 12201-2 and EN 12666-1.				

⁹ It is recommended only to use gypsum plaster or cementitious mortar as annular gap seal for PVC-C pipes together with sound decoupling according to B.6

¹⁰ In Germany the pipes have additionally to comply with DIN 19531-10

¹¹ In Germany the pipes have additionally to comply with DIN 19535-10.

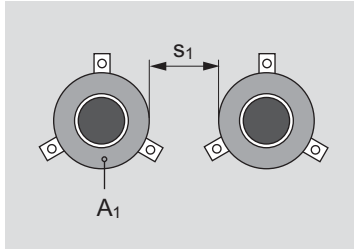
C.2 Rigid walls according to 1.2.1, minimum wall thickness 150 mm				
Penetration seal: Single penetration; Hilti Firestop Collar CFS-C on both sides (A_1), annular gap filled with Hilti Firestop Acrylic Sealant CFS-S ACR (A_2) with a depth of minimum 10 mm from the surface of the wall, backfilled with mineral wool. Minimum distance between collars / annular gap (s_1): 200 mm Width of annular gap: The opening diameter should not be larger than the collar outside diameter to allow a safe fixing of the collar to the wall except stated otherwise in the tables below. Collars fixed by hooks (F) and metal anchors with minimum \varnothing 8 mm. In low density rigid walls threaded rods M8 through the wall fixed with nuts on both sides of the wall are to be used. For minimum number of hooks see table below. For further construction details see C.1.				
				
Penetrating services				
C.2.1 PVC-U pipes according to EN ISO 15493, EN ISO 1452 and DIN 8061/8062				
Distance between pipe and seal edge in wall (width of annular gap): ≤ 10 mm				
Pipe diameter d_c (mm)	Pipe wall thickness t_c (mm)	Collar size (A_1)	No. of hooks	Classification
50	1,8	CFS-C 50/1.5"	2	EI 180-U/C
160	3,2 – 11,9	CFS-C 160/6"	4	EI 180-U/C
The results are also valid for PVC-C pipes according to EN 1566-1 ⁹ and PVC-U pipes according to EN 1329-1 ¹⁰ and EN 1453-1 ¹⁰ .				
C.2.2 PE pipes according to EN ISO 15494 and DIN 8074/8075				
Distance between pipe and seal edge in wall (width of annular gap): ≤ 10 mm				
Pipe diameter d_c (mm)	Pipe wall thickness t_c (mm)	Collar size (A_1)	No. of hooks	Classification
50	2,9	CFS-C 50/1.5"	2	EI 180-U/C
160	4,0 – 14,6	CFS-C 160/6"	4	EI 180-U/C

C.3 Rigid floor according to 1.2.1

Penetration seal:

Single penetration;

Hilti Firestop Collar CFS-C (A_1) on the underside of the floor, annular gap filled either with gypsum plaster or cementitious mortar (A_3) over the entire thickness of the floor or with Hilti Firestop Acrylic Sealant CFS-S ACR (A_2) on both sides with a depth of minimum 10 mm, backfilled with mineral wool

Minimum distance between collars (s_1): 200 mm

Width of annular gap: The opening diameter should not be larger than the collar outside diameter to allow a safe fixing of the collar to the floor except stated otherwise in the tables below.

Collars fixed by hooks (for minimum number see table below) and metal anchors with minimum \varnothing 6 mm (up to collar size 110/4" and minimum \varnothing 8 mm (from collar size 125/5" to 250/10"). In low density rigid floors threaded rods M8 through the floor fixed with nuts on both sides of the floor are to be used.

Sound decoupling: maximum thickness 5 mm (C_1 - used in combination with gypsum plaster or mortar).

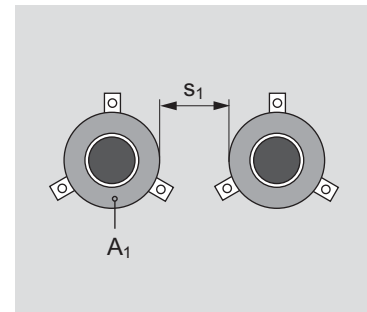

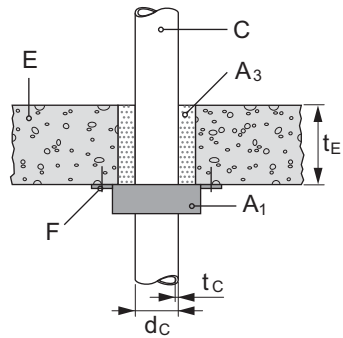
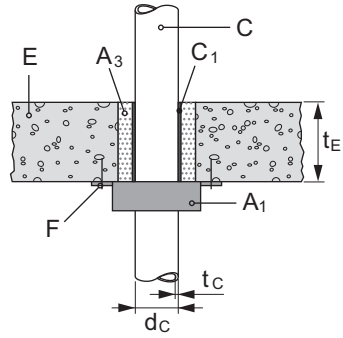
Annular gap seal	
Cementitious mortar (A_3)	
Cementitious mortar (A_3) together with sound decoupling (C_1)	

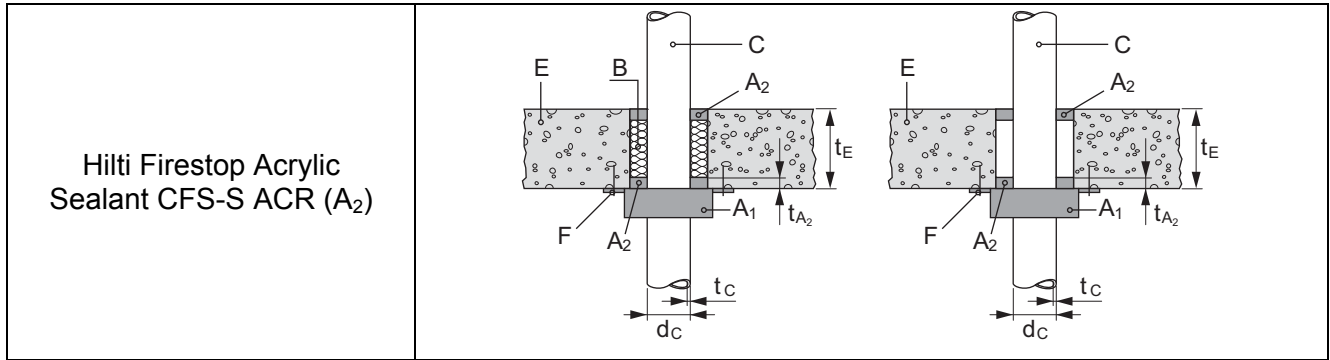

C.3.1 Rigid floor type A according to 1.2.1 (density $\geq 2400 \text{ kg/m}^3$), minimum floor thickness 200 mm				
Penetrating services				
C.3.1.1 PVC-U pipes according EN ISO 15493, EN ISO 1452 and DIN 8061/8062				
Distance between pipe and seal edge in floor (width of annular gap): $\leq 11 \text{ mm}$				
Pipe diameter d_c (mm)	Pipe wall thickness t_c (mm)	Collar size (A ₁)	No. of hooks	Classification
50	2,4 – 5,6	CFS-C 50/1.5"	2	EI 180-U/C
63	3,0 – 4,7	CFS-C 63/2"	2	EI 180-U/C
75	2,2 – 3,6	CFS-C 75/2.5"	3	EI 180-U/C
90	2,7 – 4,3	CFS-C 90/3"	3	EI 180-U/C
110	1,8 – 8,1	CFS-C 110/4"	4	EI 180-U/C
125	3,7 – 6,0	CFS-C 125/5"	4	EI 180-U/C
160	2,5 – 11,8	CFS-C 160/6"	4	EI 180-U/C
The results are also valid for PVC-C pipes according to EN 1566-1 ⁹ and PVC-U pipes according EN 1329-1 ¹⁰ and EN 1453-1 ¹⁰ .				
C.3.1.2 PE pipes according to EN ISO 15494 and DIN 8074/8075				
Distance between pipe and seal edge in floor (width of annular gap): $\leq 11 \text{ mm}$				
Pipe diameter d_c (mm)	Pipe wall thickness t_c (mm)	Collar size (A ₁)	No. of hooks	Classification
50	2,9 – 4,6	CFS-C 50/1.5"	2	EI 180-U/C
63	1,8 – 5,8	CFS-C 63/2"	2	EI 180-U/C
75	1,9 – 6,8	CFS-C 75/2.5"	3	EI 180-U/C
90	2,2 – 8,2	CFS-C 90/3"	3	EI 180-U/C
110	2,7 – 10,0	CFS-C 110/4"	4	EI 180-U/C
125	3,1 – 7,1	CFS-C 125/5"	4	EI 180-U/C
160	4,0 – 9,1	CFS-C 160/6"	4	EI 180-U/C

C.3.2 Rigid floor type A according to 1.2.1 (density $\geq 2400 \text{ kg/m}^3$), minimum floor thickness 150 mm				
Penetrating services				
C.3.2.1 PVC-U pipes according to EN ISO 15493, EN ISO 1452 and DIN 8061/8062				
Width of annular gap: The opening diameter should not be larger than the collar outside diameter to allow a safe fixing of the collar to the wall.				
Pipe diameter d_c (mm)	Pipe wall thickness t_c (mm)	Collar size (A_1)	No. of hooks	Classification
50	2,4	CFS-C 50/1.5"	2	EI 120-U/C
75	2,2	CFS-C 75/2.5"	3	EI 120-U/C
90	2,7	CFS-C 90/3"	3	EI 120-U/C
125	3,7	CFS-C 125/5"	4	EI 120-U/C
160	2,5 – 11,8	CFS-C 160/6"	4	EI 120-U/C
The results are also valid for PVC-C pipes according to EN 1566-1 ⁹ and PVC-U pipes according to EN 1329-1 ¹⁰ and EN 1453-1 ¹⁰ .				
C.3.2.2 PE pipes according to EN ISO 15494 and DIN 8074/8075				
Width of annular gap: The opening diameter should not be larger than the collar outside diameter to allow a safe fixing of the collar to the wall.				
Pipe diameter d_c (mm)	Pipe wall thickness t_c (mm)	Collar size (A_1)	No. of hooks	Classification
75	1,9 – 6,8	CFS-C 75/2.5"	3	EI 120-U/C
160	4,0 – 9,1	CFS-C 160/6"	4	EI 90-U/C
160	9,1	CFS-C 160/6"	4	EI 120-U/C
C.3.2.3 PE pipes according to EN 1519-1¹¹				
Width of annular gap: The opening diameter should not be larger than the collar outside diameter to allow a safe fixing of the collar to the wall.				
Pipe diameter d_c (mm)	Pipe wall thickness t_c (mm)	Collar size (A_1)	No. of hooks	Classification
50	3,0	CFS-C 50/1.5"	2	EI 120-U/C
63	3,0	CFS-C 63/2"	2	EI 120-U/C
75	3,0	CFS-C 75/2.5"	3	EI 120-U/C
90	3,5	CFS-C 90/3"	3	EI 120-U/C
110	4,2	CFS-C 110/4"	4	EI 120-U/C
125	4,8	CFS-C 125/5"	4	EI 120-U/C
160	6,2	CFS-C 160/6"	4	EI 120-U/C
The results are also valid for PE pipes according to EN 12201-2 and EN 12666-1.				

C.3.2.4 PVC-U pipes according to EN ISO 15493, EN ISO 1452 and DIN 8061/8062				
Distance between pipe and seal edge in floor (width of annular gap): ≤ 10 mm				
Pipe diameter d_c (mm)	Pipe wall thickness t_c (mm)	Collar size (A_1)	No. of hooks	Classification
50	1,8	CFS-C 50/1.5"	2	EI 180-U/C
160	3,2 – 11,9	CFS-C 160/6"	4	EI 180-U/C
The results are also valid for PVC-C pipes according to EN 1566-1 ⁹ and PVC-U pipes according to EN 1329-1 ¹⁰ and EN 1453-1 ¹⁰ .				
C.3.2.5 PE pipes according to EN ISO 15494 and DIN 8074/8075				
Distance between pipe and seal edge in floor (width of annular gap): ≤ 10 mm				
Pipe diameter d_c (mm)	Pipe wall thickness t_c (mm)	Collar size (A_1)	No. of hooks	Classification
50	2,9	CFS-C 50/1.5"	2	EI 180-U/C
160	4,0 – 14,6	CFS-C 160/6"	4	EI 180-U/C
C.3.3 Rigid floor type B according to 1.2.1 (density ≥ 550 kg/m³), minimum floor thickness 150 mm				
Penetrating services				
C.3.3.1 PVC-U pipes according to EN ISO 15493, EN ISO 1452 and DIN 8061/8062				
Width of annular gap: The opening diameter should not be larger than the collar outside diameter to allow a safe fixing of the collar to the wall.				
Pipe diameter d_c (mm)	Pipe wall thickness t_c (mm)	Collar size (A_1)	No. of hooks	Classification
50	2,4	CFS-C 50/1.5"	2	EI 120-U/C
75	2,2	CFS-C 75/2.5"	3	EI 120-U/C
90	2,7	CFS-C 90/3"	3	EI 120-U/C
125	3,7	CFS-C 125/5"	4	EI 120-U/C
160	2,5 – 11,8	CFS-C 160/6"	4	EI 120-U/C
The results are also valid for PVC-C pipes according to EN 1566-1 ⁹ and PVC-U pipes according to EN 1329-1 ¹⁰ and EN 1453-1 ¹⁰ .				
C.3.3.2 PE pipes according to EN ISO 15494 and DIN 8074/8075				
Width of annular gap: The opening diameter should not be larger than the collar outside diameter to allow a safe fixing of the collar to the wall.				
Pipe diameter d_c (mm)	Pipe wall thickness t_c (mm)	Collar size (A_1)	No. of hooks	Classification
75	1,9 – 6,8	CFS-C 75/2.5"	3	EI 120-U/C
160	4,0 – 9,1	CFS-C 160/6"	4	EI 90-U/C
160	9,1	CFS-C 160/6"	4	EI 120-U/C

blank page