

ÖSTERREICHISCHES INSTITUT FÜR BAUTECHNIK

A-1010 Vienna, Schenkenstrasse 4
Tel.: + 4 3 (0) 1 - 5 3 3 6 5 5 0
Fax: + 4 3 (0) 1 - 5 3 3 6 4 2 3
E-mail: mail@oib.or.at

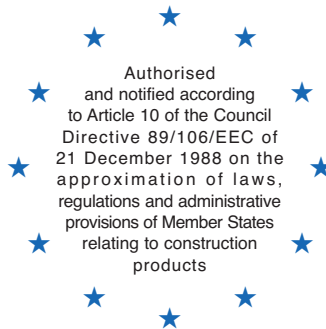

Member of EOTA

European technical approval

ETA-10/0406

(English language translation, the original version is in German language)

Handelsbezeichnung:
Trade name:

Hilti Firestop Intumescent Sealant CFS-IS

Zulassungsinhaber:
Holder of approval:

**Hilti AG
Feldkircherstrasse 100
9494 Schaan
Liechtenstein**

Zulassungsgegenstand
und Verwendungszweck:

Abschottungen

*Generic type and use of
construction product:*

Penetration seals

Geltungsdauer vom:
Validity from:
bis:
to:

22.02.2011

21.02.2016

Herstellwerk:
Manufacturing plant:

Hilti Werk 4a

Diese Europäische
technische Zulassung umfasst:
*This European technical
approval contains:*

19 Seiten inklusive **3** Anhängen

19 pages including **3** Annexes



European Organisation for Technical Approvals
Europäische Organisation für Technische Zulassungen
Organisation Européenne pour l'Agrément technique

I LEGAL BASES AND GENERAL CONDITIONS

- 1 This European technical approval is issued by Österreichisches Institut für Bautechnik in accordance with:
 - Council Directive 89/106/EEC of 21 December 1988 on the approximation of laws, regulations and administrative provisions of Member States relating to construction products¹ modified by Council Directive 93/68/EEC² and Regulation (EC) N° 1882/2003 of the European Parliament and of the Council³;
 - Bauproduktengesetz. LGBl. V Nr. 33/1994;
 - Common Procedural Rules for Requesting, Preparing and the Granting of European technical approvals set out in the Annex to Commission Decision 94/23/EC⁴;
 - Guideline for European technical approval of Fire Stopping and Fire Sealing Products: Part 2: Penetration Seals.
- 2 The Österreichisches Institut für Bautechnik is authorized to check whether the provisions of this European technical approval are met. Checking may take place in the manufacturing plant(s). Nevertheless, the responsibility for the conformity of the products to the European technical approval and for their fitness for the intended use remains with the holder of the European technical approval.
- 3 This European technical approval is not to be transferred to manufacturers or agents of manufacturers other than those indicated on page 1, or manufacturing plants other than those indicated on page 1 of this European technical approval.
- 4 This European technical approval may be withdrawn by Österreichisches Institut für Bautechnik, in particular pursuant to information by the Commission according to Article 5(1) of Council Directive 89/106/EEC.
- 5 Reproduction of this European technical approval including transmission by electronic means shall be in full. However, partial reproduction can be made with the written consent of Österreichisches Institut für Bautechnik. In this case partial reproduction has to be designated as such. Texts and drawings of advertising brochures shall not contradict or misuse the European technical approval.
- 6 The European technical approval is issued by the approval body in English. This version corresponds fully to the version circulated in EOTA. Translations into other languages have to be designated as such.

¹ Official Journal of the European Communities N° L 40, 11.2.1989, p. 12

² Official Journal of the European Communities N° L 220, 30.8.1993, p. 1

³ Official Journal of the European Union N° L 284, 31.10.2003, p.1

⁴ Official Journal of the European Communities N° L 17, 20.1.1994, p. 34

II SPECIFIC CONDITIONS OF THE EUROPEAN TECHNICAL APPROVAL

1 Definition of product(s) and intended use

1.1 Definition of the construction product

Hilti Firestop Intumescent Sealant CFS-IS is a product to form a penetration seal used to reinstate the fire resistance performance of wall and floor constructions, where they have been provided with apertures for the penetration of services.

Hilti Firestop Intumescent Sealant CFS-IS is a 1-component product and is composed essentially of filling substances, intumescent components and binder (acrylic). Colour: anthracite.

Hilti Firestop Intumescent Sealant CFS-IS is supplied in 310 ml cartridges. The sealant is installed in the annular space formed by the service and the edge of the opening in the building element, normally together with mineral wool as a backing material. For specification of suitable mineral wool products see Annex B.

1.2 Intended Use and Use Category

1.2.1 Intended Use

Hilti Firestop Intumescent Sealant CFS-IS may be used to provide a penetration seal around services running through square or rectangular openings of maximum dimensions $w \times h = 150 \text{ mm} \times 150 \text{ mm}$ or circular openings of an equivalent maximum area in walls and floors. Further details on the type of services covered by the declared classifications and other parameters to be considered are given in Annex C.

(1) The specific structures where Hilti Firestop Intumescent Sealant CFS-IS may be used to provide a penetration seal are as follows:

Flexible walls: The wall must have a minimum thickness of 100 mm and comprise timber or steel studs lined on both faces with minimum 2 layers of 12,5 mm thick boards. For timber stud walls there must be a minimum distance of 100 mm between the seal and any stud, and the cavity must be filled with minimum 100 mm insulation of Class A1 or A2 in accordance with EN 13501-1).

Rigid walls: The wall must have a minimum thickness of 100mm and comprise concrete, aerated concrete or masonry, with a minimum density of 550 Kg/m^3 .

Rigid floors: The floor must have a minimum thickness of 150 mm and comprise aerated concrete or concrete with a minimum density of 550 Kg/m^3 .

The supporting construction must be classified in accordance with EN 13501-2 for the required fire resistance period.

This ETA does not cover use of this product as a penetration seal in sandwich panel constructions.

(2) Hilti Firestop Intumescent Sealant CFS-IS may be used to provide a penetration seal with the following specific services:

Blank seal	as given in Annex C
Cables / conduits	Services as given in Annex C

(3) The first support of the cables / conduits shall be located at maximum 250 mm away from both faces of wall constructions and maximum 250 mm from the upper face of floor constructions.

The provisions made in this European technical approval are based on an assumed working life of Hilti Firestop Intumescent Sealant CFS-IS of 10 years, provided that the conditions laid down in sections 4.2/5.1/5.2 for the packaging / transport / storage / installation / use / repair are met. The indications given on the working life cannot be interpreted as a guarantee given by the producer, but are to be regarded only as a means for choosing the right products in relation to the expected economically reasonable working life of the works.

1.2.2 Use Category

The use category of Hilti Firestop Intumescent Sealant CFS-IS is Type Y_{2, (-5/+70)°C}. Since the requirements for type Y₂ are met, also the requirements for type Z₁ and Z₂ are fulfilled.

Type Y₂: Products for penetration seals intended for use at temperatures between -5 °C and + 70°C, but with no exposure to rain nor UV.

Type Z₁: Products for penetration seals intended for use at internal conditions with high humidity, excluding temperatures below 0°C.⁵

Type Z₂: Products for penetration seals intended for uses at internal conditions with humidity classes other than Z₁, excluding temperatures below 0°C.

2 Characteristics of the product and methods of verification

The identification tests and the assessment of the fitness for use according to the Essential Requirements were carried out in compliance with the “ETA Guidance no. 026-Part 2” concerning Penetration Seals – edition January 2008 (called ETAG 026-2 in this ETA).

ETAG Clause No.	ETA Clause No.	Characteristic	Assessment of characteristic
		Mechanical resistance and stability	Not relevant
		Safety in case of fire	
2.4.1	2.1	Reaction to fire	Class E according to EN 13501-1
2.4.2	2.2	Resistance to fire	See clause 2.2
		Hygiene, Health and the Environment	
2.4.3	2.3	Air permeability	Air and gas tight
2.4.4	2.4	Water permeability	No performance determined
2.4.5	2.5	Dangerous substances	See clause 2.5
		Safety in use	
2.4.6	2.6	Mechanical resistance and stability	No performance determined
2.4.7	2.7	Resistance to impact/movement	No performance determined
2.4.8	2.8	Adhesion	No performance determined
		Protection against noise	
2.4.9	2.9	Airborne sound insulation	No performance determined

⁵ These uses apply for internal humidity class 5 in accordance with EN ISO 13788

		Energy, Economy and Heat Retention	
2.4.10		Thermal properties	No performance determined
2.4.11		Water vapour permeability	No performance determined
		General aspects relating to fitness for use	
2.4.12		Durability and serviceability	Y ₂ , (-5/+70)°C

2.1 Reaction to fire

The reaction to fire classification for Hilti Firestop Intumescent Sealant CFS-IS in the cured state is class E according to EN 13501-1.

2.2 Resistance to fire

The classification of the resistance to fire performance has been carried out in accordance with clause 7.5.8 in EN 13501-2:2007. Penetration seals made from Hilti Firestop Intumescent Sealant CFS-IS are classified according to combinations of performance parameters and classes as shown in Annex C. The classifications are valid for services running through square or rectangular openings of maximum dimensions $w \times h = 150 \text{ mm} \times 150 \text{ mm}$ or circular openings of an equivalent maximum area, in flexible and rigid walls with minimum thickness $t_E = 100 \text{ mm}$ and 150 mm respectively and concrete floors with minimum thickness 150 mm . The classifications require that the rules for installation shown in cl. 4.2 are followed.

The classifications are not valid for sandwich panel constructions.

2.3 Air permeability

The air permeability has been tested according to EN 1026.

Hilti Firestop Intumescent Sealant CFS-IS is impermeable for air, N₂, CO₂ and CH₄ (Methane).

The permeability regarding the gases listed above has been determined for 50 mm thickness of Hilti Firestop Intumescent Sealant CFS-IS.

The result refers to a body of pure Hilti Firestop Intumescent Sealant CFS-IS without any penetrating installation.

2.4 Water permeability

No performance determined

2.5 Dangerous substances

According to the manufacturer's declaration, the product specification has been compared with the list of dangerous substances of the European Commission to verify that that it does not contain such substances above the acceptable limits.

A written declaration in this respect was submitted by the ETA-holder.

In addition to the specific clauses relating to dangerous substances contained in this ETA, there may be other requirements applicable to the products falling within its scope (e.g. transposed European legislation and national laws, regulations and administrative provisions). In order to meet the provisions of the Construction Product Directive, these requirements need also to be complied with, when and where they apply.

2.5 Mechanical resistance and stability

No performance determined.

2.6 Resistance to impact/movement

No performance determined.

2.7 Adhesion

No performance determined.

2.8 Airborne sound insulation

No performance determined.

2.9 Thermal properties

No performance determined.

2.10 Water vapour permeability

No performance determined.

2.12 Durability and serviceability

2.12.1 Durability

Hilti Firestop Intumescent Sealant CFS-IS has been tested in accordance with EOTA technical Report - TR024 - Edition November 2006, Table 4.1, for the type Y₂ use category specified in EOTA 026-2. The results of the tests have demonstrated suitability for penetration seals intended for use at temperatures between -5°C and +70°C, but with no exposure to rain nor UV (Y₂, (-5/+70)°C).

2.12.2 Serviceability

2.12.2.1 Electrical properties

- Volume resistivity (according to DIN IEC 93 (VDE 0303 Part 30):1993-12): 164E+10 ± 55E+10 Ω.cm.
- Surface resistivity (according to DIN IEC 93 (VDE 0303 Part 30):1993-12): 318E+06 ± 84E+06 Ω.
-

3 Evaluation of Conformity and CE marking

3.1 Attestation of Conformity system

According to the decision 1999/454/EC of the European Commission⁶ the system 1 of attestation of conformity applies.

This system of attestation of conformity is defined as follows:

System 1: Certification of the conformity of the product by a notified certification body on the basis of:

⁶ Official Journal of the European Communities N° L 178, 14.7.1999, p. 52

- (a) Tasks for the manufacturer:
 - (1) factory production control;
 - (2) further testing of samples taken at the factory by the manufacturer in accordance with a prescribed test plan;
- (b) Tasks for the notified body
 - (3) initial type-testing of the product;
 - (4) initial inspection of factory and of factory production control;
 - (5) continuous surveillance, assessment and approval of factory production control.

3.2 Responsibilities

3.2.1 Tasks of the Manufacturer

3.2.1.1 Factory production control

The manufacturer shall exercise permanent internal control of production. All the elements, requirements and provisions adopted by the manufacturer shall be documented in a systematic manner in the form of written policies and procedures, including records of results performed. This production control system shall insure that the product is in conformity with this European technical approval.

The manufacturer shall draw up and keep up-to-date documents defining the factory production control that applies. The documentation to be carried out by the manufacturer and the applicable procedures shall be appropriate to the product and manufacturing process. The factory production control shall ensure the conformity of the product to an appropriate level. This involves:

- a) the preparation of documented procedures and instructions relating to factory production control operations.
- b) the effective implementation of these procedures and instructions.
- c) the recording of these procedures and their results.
- d) the use of these results to correct any deviations, repair the effects of such deviations, treat any resulting instances of non-conformity and, if necessary, revise the factory production control to rectify the cause of non-conformity.
- e) a procedure to ensure that both the approval Body and the Notified (Certification) Bodies are advised before any significant change to the product, its components or manufacturing process, is made.
- f) a procedure to ensure that personnel involved in the production processes and the quality control procedures are qualified and adequately trained to carry out their required tasks.
- g) that all testing and measuring equipment is maintained and up to date calibration records are documented.
- h) maintenance of records to ensure every batch produced is clearly labelled with the batch number, which allows traceability to its production to be identified.

The manufacturer may only use components stated in the technical documentation of this European technical approval.

For the components which the ETA-holder does not manufacture by himself, he shall make sure that factory production control carried out by the other manufacturers gives the guaranty of the components compliance with the European technical approval.

The factory production control of the ETA holder and the provisions taken by the ETA-holder for components not produced by himself shall be in accordance with the control plan⁷ relating to this European technical approval which is part of the technical documentation of this European technical approval. The "Control Plan" is laid down in the context of the factory production control system operated by the manufacturer and deposited at the Österreichisches Institut für Bautechnik.

The results of factory production control shall be recorded and evaluated in accordance with the provisions of the control plan.

3.2.1.2 Other tasks of manufacturer

The manufacturer shall, on the basis of a contract, involve a body (bodies) which is (are) approved for the tasks referred to in section 3.1 in the field of penetration seals in order to undertake the actions laid down in section 3.3. For this purpose, the "control plan" referred to in sections 3.2.1.1 and 3.2.2 shall be handed over by the manufacturer to the approved body or bodies involved.

The manufacturer shall make a declaration of conformity, stating that the construction product is in conformity with the provisions of this European technical approval.

Additional information

The manufacturer shall provide a technical data sheet and an installation instruction with the following minimum information:

technical data sheet:

- Field of application:
 - Building elements for which the penetration seal is suitable, type and properties of the building elements like minimum thickness, density, and - in case of lightweight constructions – the construction requirements.
 - Services for which the penetration seal is suitable, type and properties of the services like material, diameter, thickness etc. in case of pipes including insulation materials; necessary/allowed supports/fixings (e.g. cable trays)
 - Limits in size, minimum thickness etc. of the penetration seal
- Construction of the penetration seal including the necessary components and additional products (e.g. backfilling material) with clear indication whether they are generic or specific.

Installation instruction:

- Steps to be followed
- Procedure in case of retrofitting.

3.2.2 Tasks of Notified Bodies

The Notified Body (Bodies) shall perform the

- initial type-testing of the product (for system 1),
The results of the tests performed as part of the assessment for the European technical approval may be used unless there are changes in the production line or plant. In such cases, the necessary initial type testing has to be agreed between the Österreichisches Institut für Bautechnik and the Notified Bodies involved.
- initial inspection of factory and of factory production control,
The Notified Body (Bodies) shall ascertain that, in accordance with the control plan, the factory (in particular the employees and the equipment) and the factory production

⁷ The control plan is a confidential part of the European Technical Approval and only handed over to the Notified Body or Bodies involved in the procedure of conformity.

control are suitable to ensure continuous and orderly manufacturing of the components according to the specifications mentioned in clause 2 of this ETA.

- continuous surveillance, assessment and approval of factory production control, The Notified Body (Bodies) shall visit the factory at least once a year for surveillance of this manufacturer having a FPC system complying with a quality management system covering the manufacturing of the approval product components. It has to be verified that the system of factory production control and the specified automated manufacturing process are maintained taking into account the control plan.

These tasks shall be performed in accordance with the provisions laid down in the control plan of this European technical approval.

The Notified Body (Bodies) shall retain the essential points of its (their) actions referred to above and state the results obtained and conclusions drawn in a written report.

The Notified Body involved by the manufacturer shall issue an EC certificate of conformity of the product stating the conformity with the provisions of this European technical approval.

In cases where the provisions of the European technical approval and its control plan are no longer fulfilled the certification body shall withdraw the certificate of conformity and inform the Österreichisches Institut für Bautechnik without delay.

3.3 CE marking

The CE marking shall be affixed on the product itself, on a label attached to it, on its packaging or on the commercial documents accompanying the components of the product. The letters „CE“ shall be followed by the identification number of the Notified Body involved and be accompanied by the following additional information:

- the name or identifying mark and address of the ETA holder,
- the last two digits of the year in which the CE marking was affixed,
- the number of the EC certificate of conformity for the product,
- the number of the European technical approval,
- the number of the ETAG (ETAG N° 026 part 2)
- the designation of the product (trade name)
- the use category in accordance with the ETA section 1 and 2
- “see ETA-10/0406 for other relevant characteristics (e.g. resistance to fire)”

4 Assumptions under which the fitness of the product(s) for the intended use was favourably assessed

4.1 Manufacturing

The European technical approval is issued for the product on the basis of agreed data/information, deposited with Österreichisches Institut für Bautechnik, which identifies the product that has been assessed and judged. Changes to the product or production process, which could result in this deposited data/information being incorrect, should be notified to Österreichisches Institut für Bautechnik before the changes are introduced. Österreichisches Institut für Bautechnik will decide whether or not such changes affect the ETA and consequently the validity of the CE marking on the basis of the ETA and if so whether further assessment or alterations to the ETA, shall be necessary.

4.2 Installation

The ETA is issued under the assumption that the installation of the approval product shall be in accordance with the manufacturer’s technical literature.

Installation of the Hilti Firestop Intumescent Sealant CFS-IS must be conducted as follows:

- Clean opening. Surfaces to which Hilti Firestop Intumescent Sealant CFS-IS will be applied should be cleaned of loose debris, dirt, oil, wax and grease.

- Hilti Firestop Intumescent Sealant CFS-IS adheres to most substrates (concrete, masonry, drywall, plaster, etc.) without using a primer. For very brittle and porous substrates, a prior coating of Hilti Firestop Intumescent Sealant CFS-IS diluted with water is recommended as a primer. Other primers are not necessary.
- Insert backfilling material. Leave sufficient depth for application of the sealant.
- As backfilling material loose stone wool must be applied. For suitable products see Annex B. The wool must be tightened thoroughly.
- Apply Hilti Firestop Intumescent Sealant CFS-IS using a manual dispenser (e.g. Hilti CB 200-P1).
- Smooth the sealant. Use either a diluted liquid soap or smoothing agent and carefully smooth using a finger or narrow spatula.
- Repeat installation on the other side of the wall.
- The sealant depth is described in Annex C

5 Indications to the manufacturer

5.1 Packaging, transport and storage

In the accompanying document and/or on the packaging the manufacturer shall give information as to transport and storage.

At least the following shall be indicated: storing temperature, type of storage, maximum duration of storage and required data related to minimum temperature for transport and storage.

5.2 Use, maintenance, repair

The Hilti Firestop Intumescent Sealant CFS-IS should be installed and used as described earlier in this document.

The assessment of the fitness for use is based on the assumption that damage, for example caused by accidental impact, is repaired. The relevant manufacturer instructions shall be followed.

Storage/transport:

Transport and storage temperature: +5°C to +25°C.

CFS-IS has to be stored dry in its original packaging.

On behalf of Österreichisches Institut für Bautechnik

Rainer Mikulits
Managing Director

ANNEX A

REFERENCE DOCUMENTS and LIST OF ABBREVIATIONS

A.1 References to standards mentioned in the ETA

DIN IEC 60093 (VDE 0303 Part 30)	Methods of test for insulating materials for electrical purposes: Volume resistivity and surface resistivity of solid electrical insulating materials
EN 1026	Windows and doors – Air permeability – Test method
EN 13501-1	Fire classification of construction products and building elements – Part 1: Classification using test data from reaction to fire tests
EN 13501-2	Fire classification of construction products and building elements – Part 2: Classification using test data from fire resistance tests

A.2 Other reference documents

EOTA TR 024	Characterisation, Aspects of Durability and Factory Production Control for Reactive Materials, Components and Products
-------------	--

A.3 Abbreviations used in drawings

Abbreviation	Description
A	Firestop product
B	Backfilling material
E	Building element (wall, floor)
h	Height/length of penetration seal
L _A	Length of additional Hilti Firestop Intumescent Sealant CFS-IS in front of the wall/floor
s ₁ , s ₂	Distances
t _A , t _{1A}	Thickness (depth) of penetration seal
t _{2A}	Thickness of additional Hilti Firestop Intumescent Sealant CFS-IS in front of the wall/floor
t _B	Thickness (depth) of backfilling material
t _E	Thickness of the building element
w	Width of penetration seal

ANNEX B

DESCRIPTION OF PRODUCT(S) & PRODUCT LITERATURE

B.1 Hilti Firestop Intumescent Sealant CFS-IS

A detailed specification of the product is contained in document "Identification / Product Specification relating to the European technical approval ETA – 10/0406, Hilti Firestop Intumescent Sealant CFS-IS" which is a non-public part of this ETA.

The Control Plan is defined in document "Control Plan relating to the European technical approval ETA-10/0406 - Hilti Firestop Intumescent Sealant CFS-IS" which is a non-public part of this ETA.

Technical product literature:

- Technical data sheet and instructions for use Hilti Firestop Intumescent Sealant CFS-IS

B.2 Mineral Wool

Loose mineral wool products suitable for being used as backfilling material

Product	Manufacturer	Specification
Heralan LS	Knauf Insulation GmbH	Product data sheet of manufacturer
Isover loose wool SL	Saint-Gobain ISOVER	Product data sheet of manufacturer
Isover Universal-Stopfwolle	Saint-Gobain ISOVER	Product data sheet of manufacturer
Rockwool RL	Rockwool	Product data sheet of manufacturer
Paroc Pro Loose Wool	Paroc OY AB	Product data sheet of manufacturer

ANNEX C

RESISTANCE TO FIRE CLASSIFICATION OF PENETRATION SEALS MADE FROM HILTI FIRESTOP INTUMESCENT SEALANT CFS-IS

C.1 Flexible wall constructions according to 1.2.1

Penetration seal:

Hilti Firestop Intumescent Sealant CFS-IS (A) on both sides, thickness (t_A) 25 mm, mineral wool (B) tightly compressed as backfilling material, thickness (t_B) ≥ 50 mm (gap filled completely).

For suitable products for mineral wool backfilling see Annex B.

Maximum seal size: 150 x 150 mm or circular openings of equivalent area.

Minimum distances (mm):

Cables to edge of seal	$s_1 = 0$
Cable to other cables/services	$s_2 = 0$
Tied cable bundle to seal edge	$s_1 = 10$
Tied cable bundle to other services	$s_2 = 0$
Small conduits/tubes to edge of seal	$s_1 = 10$
Small conduits/tubes to other services	$s_2 = 0$
Conduits $16 \leq \varnothing \leq 32$ mm to edge of seal	$s_1 = 10$
Conduits $16 \leq \varnothing \leq 32$ mm to other services	$s_2 = 10$

Construction details:

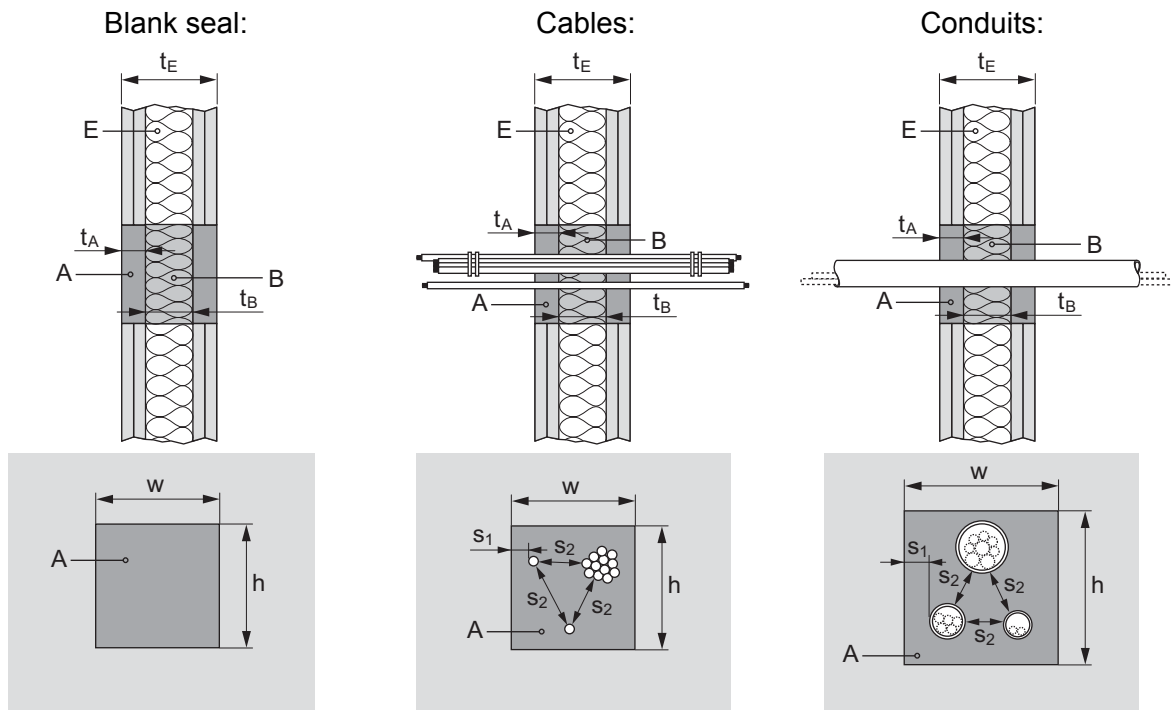

For explanation of abbreviations see the related text and Annex A

Services	Classification
C.1.1 Blank seal	EI 120 *)
<p>*) If cables are added later on only cables with a diameter < 21 mm, small conduits/tubes according to C.1.3.1 and C.1.3.2 and conduits according to C.1.3.3 may be added if the required classification is EI 120.</p> <p>If the seal is used in a wall with a requirement of EI 90 tied cable bundles according to C.1.2 may be added later on.</p> <p>If the seal is used in a wall with a requirement of EI 60 or EI 30 all types of cables according to C.1.2 may be added later on.</p>	
C.1.2 Cables	Classification
<p>All sheathed cable types currently and commonly used in building practice in Europe (e.g. power, control, signal, telecommunication, data, optical fibre cables) with a diameter of:</p>	
Maximum Ø 21 mm	EI 120
21 ≤ Ø ≤ 80 mm	EI 60
Tied cable bundle ⁸ , maximum diameter of 100 mm, maximum diameter of single cable 21 mm	EI 90
C.1.3 Conduits	Classification
C.1.3.1 Small steel conduits and tubes, diameter ≤ 16 mm, arranged linear, with or without cables	EI 120-C/U
C.1.3.2 Small plastic conduits and tubes, diameter ≤ 16 mm, arranged linear, with or without cables	EI 120-U/C
C.1.3.3 Plastic conduits, diameter 16 ≤ Ø ≤ 32 mm, wall thickness 1 – 3 mm, arranged linear or in a cluster, with or without cables	EI 120-U/C

⁸ Several cables running in the same direction and bound closely together by mechanical means

C.2 Rigid wall constructions according to 1.2.1

Penetration seal:

Seal type 1: Hilti Firestop Intumescent Sealant CFS-IS (A) on both sides, thickness (t_A , t_{1A}) 25 mm, mineral wool (B) tightly compressed as backfilling material, thickness (t_B) ≥ 100 mm (gap filled completely).

Seal type 2: additional sealant CFS-IS ($t_{2A} \geq 10$ mm, $L_A \geq 50$ mm) on both sides.

Seal type 3: additional sealant CFS-IS ($t_{2A} \geq 10$ mm, $L_A \geq 100$ mm) on both sides.

For suitable products for mineral wool backfilling see Annex B.

Maximum seal size: 150 x 150 mm or circular openings of equivalent area.

Minimum distances (mm):

Cables to edge of seal	$s_1 = 0$
Cable to other cables/services	$s_2 = 0$
Tied cable bundle to seal edge	$s_1 = 10$
Tied cable bundle to other services	$s_2 = 0$
Small conduits/tubes to edge of seal	$s_1 = 10$
Small conduits/tubes to other services	$s_2 = 0$
Conduits $16 \leq \varnothing \leq 32$ mm to edge of seal	$s_1 = 10$
Conduits $16 \leq \varnothing \leq 32$ mm to other services	$s_2 = 10$

Construction details:

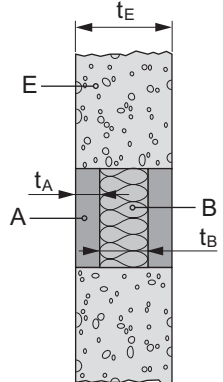
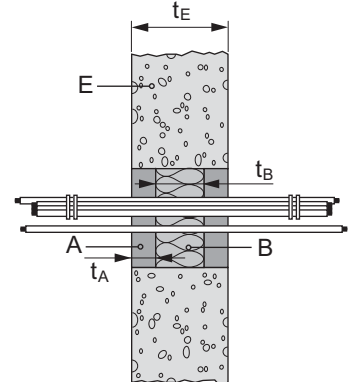
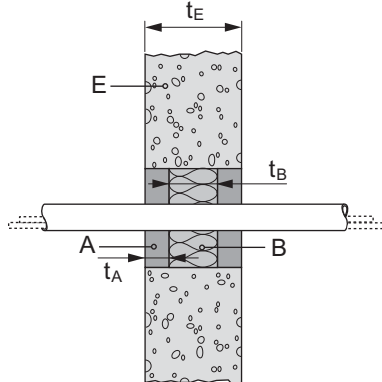
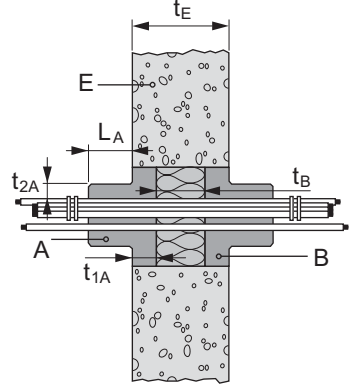
Blank seal	Cables and conduits ≤ 16 mm	Conduits $16 \leq \varnothing \leq 32$ mm
<p>Seal type 1</p> 	<p>Seal type 1</p> 	<p>Seal type 1</p> 
<p>-</p>	<p>Seal type 2 ($L_A \geq 50$ mm) Seal type 3 ($L_A \geq 100$ mm)</p> 	<p>-</p>

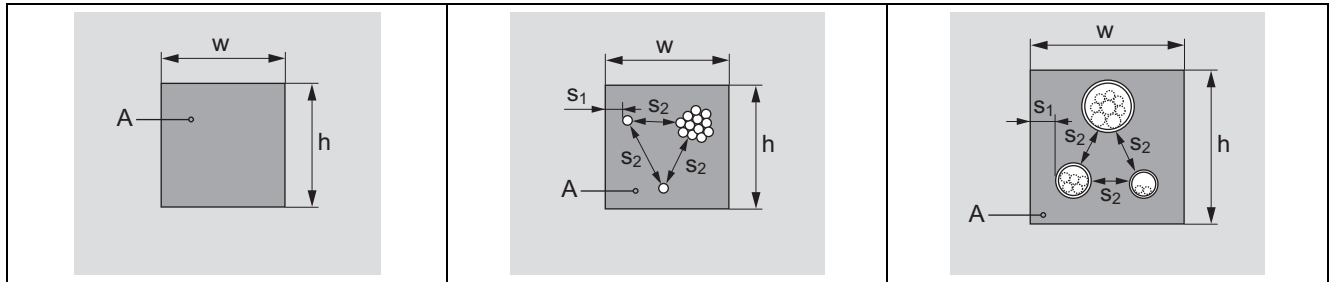

For explanation of abbreviations see the related text and Annex A

Services	Classification
C.2.1 Blank seal	EI 120 *)

*) If cables are added later on only cables with a diameter < 21 mm, tied cable bundles according to C.2.2, small conduits/tubes according to C.2.3.1 and C.2.3.2 and conduits according to C.2.3.3 may be added if the required classification is EI 120.

If the seal is used in a wall with a requirement of EI 60 or EI 30 all types of cables according to C.2.2 may be added later on.

In case additional Sealant CFS-IS is added with $L_A \geq 50 \text{ mm}$ / $t_{2A} \geq 10 \text{ mm}$ (seal type 2) all cables according to C.2.2 may be added for a requirement of EI 90.

In case additional Sealant CFS-IS is added with $L_A \geq 100 \text{ mm}$ / $t_{2A} \geq 10 \text{ mm}$ (seal type 3) all cables according to C.2.2 may be added for a requirement of EI 120.

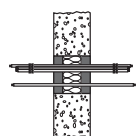
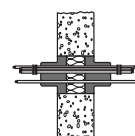
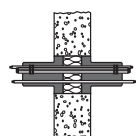
C.2.2 Cables	Classification		
	Seal type 1	Seal type 2	Seal type 3
All sheathed cable types currently and commonly used in building practice in Europe (e.g. power, control, signal, telecommunication, data, optical fibre cables) with a diameter of:			
Maximum \varnothing 21 mm	EI 90	EI 120	EI 120
$21 \leq \varnothing \leq 80 \text{ mm}$	EI 60	EI 120	EI 120
Tied cable bundle ⁹ , maximum diameter of 100 mm, maximum diameter of single cable 21 mm	EI 90	EI 120	EI 120
C.2.3 Conduits			
C.2.3.1 Small steel conduits and tubes, diameter $\leq 16 \text{ mm}$, arranged linear, with or without cables	EI 120-C/U	EI 120-C/U	EI 120-C/U
C.2.3.2 Small plastic conduits and tubes, diameter $\leq 16 \text{ mm}$, arranged linear, with or without cables	EI 120-U/C	EI 120-U/C	EI 120-U/C
C.2.3.3 Plastic conduits, diameter $16 \leq \varnothing \leq 32 \text{ mm}$, wall thickness 1 – 3 mm, arranged linear or in a cluster, with or without cables	EI 120-U/C	EI 120-U/C	EI 120-U/C

⁹ Several cables running in the same direction and bound closely together by mechanical means

C.3 Rigid floor constructions according to 1.2.1

Penetration seal:

Seal type 4: Hilti Firestop Intumescent Sealant CFS-IS (A) on top side, thickness (t_A) 25 mm, mineral wool (B) tightly compressed as backfilling material, thickness (t_B) ≥ 125 mm

Seal type 5: additional Sealant CFS-IS ($t_{2A} \geq 10$ mm, $L_A \geq 50$ mm) on top only

Seal type 6: additional Sealant CFS-IS ($t_{2A} \geq 10$ mm, $L_A \geq 100$ mm) on top only

Seal type 7: additional Sealant CFS-IS ($t_{2A} \geq 10$ mm, $L_A \geq 50$ mm) on both sides.

Seal type 8: additional Sealant CFS-IS ($t_{2A} \geq 10$ mm, $L_A \geq 100$ mm) on both sides.

For suitable products for mineral wool backfilling see Annex B.

Maximum seal size: 150 x 150 mm or circular openings of equivalent area.

Minimum distances (mm):

Cables to edge of seal	$s_1 = 0$
Cable to other cables/services	$s_2 = 0$
Tied cable bundle to seal edge	$s_1 = 10$
Tied cable bundle to other services	$s_2 = 0$
Small conduits/tubes to edge of seal	$s_1 = 20$
Small conduits/tubes to other services	$s_2 = 0$
Conduits $16 \leq \varnothing \leq 32$ mm to edge of seal	$s_1 = 10$
Conduits $16 \leq \varnothing \leq 32$ mm to other services	$s_2 = 10$

Construction details:

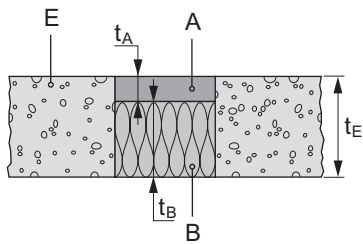
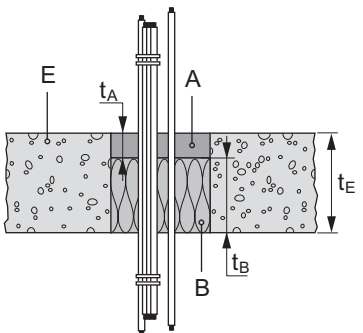
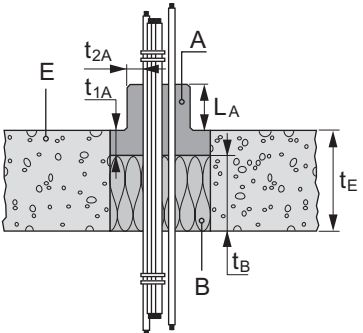
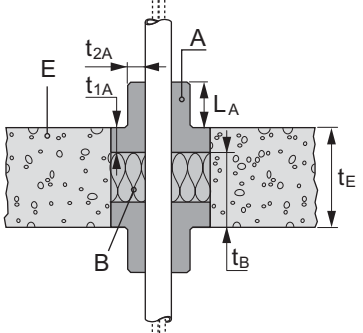
Blank seal	Cables and conduits ≤ 16 mm	Conduits $16 \leq \varnothing \leq 32$ mm
<p>Seal type 4</p> 	<p>Seal type 4</p> 	<p>-</p>
<p>-</p>	<p>Seal type 5 ($L_A \geq 50$ mm) Seal type 6 ($L_A \geq 100$ mm)</p> 	<p>Seal type 7 ($L_A \geq 50$ mm) Seal type 8 ($L_A \geq 100$ mm)</p> 

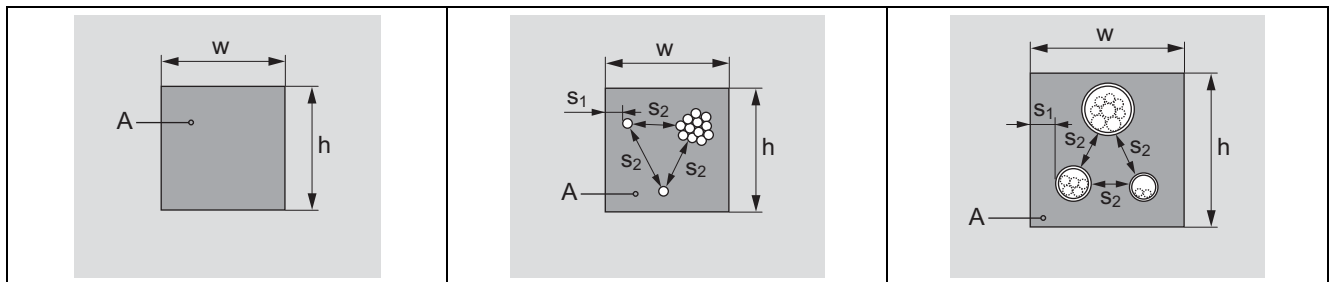

For explanation of abbreviations see the related text and Annex A

Services	Classification
C.3.1 Blank seal	EI 120 *)

*) If cables are added later on only cables with a diameter < 21 mm may be added if the required classification is EI 120.

If the seal is used in a floor with a requirement of EI 90 or less all types of cables according to C.3.2, tied cable bundles according to C.3.2 and small conduits/tubes according to C.3.3.1 and C.3.3.2 may be added later on.

In case additional Sealant CFS-IS is added with $L_A \geq 50 \text{ mm}$ / $t_{2A} \geq 10 \text{ mm}$ on top and bottom (seal type 7), conduits according to C.3.3.3 may be added for a requirement of EI 120.

In case additional Sealant CFS-IS is added with $L_A \geq 100 \text{ mm}$ / $t_{2A} \geq 10 \text{ mm}$ on top only (seal type 6), all cables according to C.3.2 may be added for a requirement of EI 120.

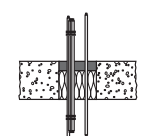
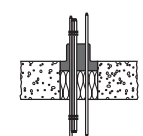
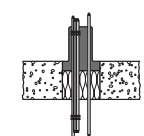
	Classification		
C.3.2 Cables	Seal type 4	Seal type 5	Seal type 6
All sheathed cable types currently and commonly used in building practice in Europe (e.g. power, control, signal, telecommunication, data, optical fibre cables) with a diameter of:			
Maximum \varnothing 21 mm	EI 120	EI 120	EI 120
$21 \leq \varnothing \leq 80 \text{ mm}$	EI 90	EI 90	EI 120
Tied cable bundle ¹⁰ , maximum diameter of 100 mm, maximum diameter of single cable 21 mm	EI 90	EI 120	EI 120

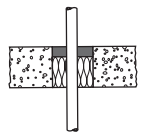
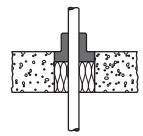
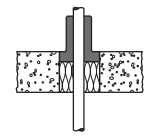
	Classification		
C.3.3 Conduits	Seal type 4	Seal type 5	Seal type 6
			
C.3.3.1 Small steel conduits and tubes, diameter $\leq 16 \text{ mm}$, arranged linear, with or without cables	EI 90-C/U	EI 120-C/U	EI 120-C/U
C.3.3.2 Small plastic conduits and tubes, diameter $\leq 16 \text{ mm}$, arranged linear, with or without cables	EI 90-U/C	EI 120-U/C	EI 120-U/C

	Classification
--	-----------------------

¹⁰ Several cables running in the same direction and bound closely together by mechanical means
 OIB-280-004/09-180

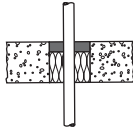
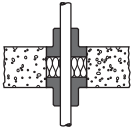
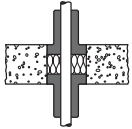
	Seal type 4 	Seal type 7 	Seal type 8 
C.3.3.3 Plastic conduits, diameter $16 \leq \varnothing \leq 32$ mm, wall thickness 1 – 3 mm, arranged linear or in a cluster, with or without cables	-	EI 120-U/C	EI 120-U/C

blank page